



SERVICE MANUAL

PMR446 FM TRANSCEIVER

IC-446S

INTRODUCTION

This service manual describes the latest service information for the **IC-446S** PMR446 FM TRANSCEIVER at the time of publication.

VERSION	SYMBOL	BODY COLOR
Europe	EUR	BLACK
	EUR-1	YELLOW
General	GEN	BLACK
	GEN-1	YELLOW

To upgrade quality, all electrical or mechanical parts and internal circuits are subject to change without notice or obligation.

DANGER

NEVER connect the transceiver to an AC outlet or to a DC power supply that uses more than 5 V. Such a connection could cause a fire hazard and/or electric shock.

DO NOT expose the transceiver to rain, snow or any liquids.

DO NOT reverse the polarities of the power supply when connecting the transceiver.

DO NOT apply an RF signal of more than 20 dBm (100mW) to the antenna connector. This could damage the transceiver's front end.

ORDERING PARTS

Be sure to include the following four points when ordering replacement parts:

1. 10-digit order numbers
2. Component part number and name
3. Equipment model name and unit name
4. Quantity required

<SAMPLE ORDER>

1110002820 S.JC NJM2100M IC-446S MAIN UNIT 5 pieces
8810009560 Screw PH BO M2x6 ZK IC-446S Chassis 10 pieces

Addresses are provided on the inside back cover for your convenience.

REPAIR NOTES

1. Make sure a problem is internal before disassembling the transceiver.
2. **DO NOT** open the transceiver until the transceiver is disconnected from its power source.
3. **DO NOT** force any of the variable components. Turn them slowly and smoothly.
4. **DO NOT** short any circuits or electronic parts. An insulated turning tool **MUST** be used for all adjustments.
5. **DO NOT** keep power ON for a long time when the transceiver is defective.
6. **DO NOT** transmit power into a signal generator or a sweep generator.
7. **ALWAYS** connect a 30 dB or 40 dB attenuator between the transceiver and a deviation meter or spectrum analyzer when using such test equipment.
8. **READ** the instructions of test equipment thoroughly before connecting equipment to the transceiver.



TABLE OF CONTENTS

SECTION 1 SPECIFICATIONS

SECTION 2 INSIDE VIEWS

SECTION 3 DISASSEMBLY INSTRUCTION

SECTION 4 CIRCUIT DESCRIPTION

4-1	RECEIVER CIRCUITS4-1
4-2	TRANSMITTER CIRCUITS4-2
4-3	PLL CIRCUITS4-2
4-4	POWER SUPPLY CIRCUITS4-3
4-5	PORT ALLOCATIONS4-3

SECTION 5 ADJUSTMENT PROCEDURES

5-1	PREPARATION5-1
5-2	PLL AND TRANSMITTER ADJUSTMENTS5-2
5-3	RECEIVER ADJUSTMENT5-3

SECTION 6 PARTS LIST

SECTION 7 MECHANICAL PARTS AND DISASSEMBLY

SECTION 8 SEMI-CONDUCTOR INFORMATION

SECTION 9 BOARD LAYOUTS

9-1	MAIN UNIT9-1
9-2	RF UNIT9-3

SECTION 10 BLOCK DIAGRAM

SECTION 11 VOLTAGE DIAGRAM

11-1	MAIN UNIT11-1
11-2	RF UNIT11-2

SECTION 1 SPECIFICATIONS

■ GENERAL

Number of channels	: 8 ch
Type of emission	: 8K50F3E
Frequency stability	: ± 2.5 kHz
Frequency resolution	: 12.5 kHz
Power supply requirements (negative ground)	: 3 \times AA(R6) dry, alkaline; or optional BP-202
Current drain	: Less than 500 mA
Operating temperature range	: -20°C to $+55^{\circ}\text{C}$
Number of CTCSS frequency	: 38 (67.0–250.3 Hz)
Dimensions (mm) (proj. not included)	: 55.5(W) \times 102.5(H) \times 26.5(D)
Weight (included 3 cells)	: 180 g

■ TRANSMITTER

Output power	: 500 mW
Modulation system	: Variable reactance frequency modulation
Max. frequency deviation	: ± 2.5 kHz
Spurious emissions	: Less than 0.25 μW
Adjacent channel power	: More than 60 dB
External mic.connector	: 3-conductor 2.5(d) mm/2.2 k Ω

■ RECEIVER

Receiving system	: Double conversion superheterodyne
Intermediate frequency	: 1st 21.7 MHz 2nd 450 kHz
Sensitivity (12 dB SINAD)	: Less than 0.25 μV ; -12 dB μV
Adjacent channel selectivity	: 55 dB
Spurious response	: 65 dB
Intermodulation	: 60 dB
Audio output power (at 4.5 V DC)	: 100 mW at 10% distortion with an 8 Ω load
External SP connector	: 2-conductor 3.5 (d) mm (1/8")/8 Ω

■ CHANNEL FREQUENCY LIST

Channel No.	Frequency (MHz)	Channel No.	Frequency (MHz)
1	446.00625	5	446.05625
2	446.01875	6	446.06875
3	446.03125	7	446.08125
4	446.04375	8	446.09375

■ CTCSS FREQUENCY LIST

Channel No.	Frequency (Hz)	Channel No.	Frequency (Hz)
1	67.0	21	136.5
2	71.9	22	141.3
3	74.4	23	146.2
4	77.0	24	151.4
5	79.7	25	156.7
6	82.5	26	162.2
7	85.4	27	167.9
8	88.5	28	173.8
9	91.5	29	179.9
10	94.8	30	186.2
11	97.4	31	192.8
12	100.0	32	203.5
13	103.5	33	210.7
14	107.2	34	218.1
15	110.9	35	225.7
16	114.8	36	233.6
17	118.8	37	241.8
18	123.0	38	250.3
19	127.3	---	OFF
20	131.8		

All stated specifications are subject to change without notice or obligation.

SECTION 2 INSIDE VIEWS

• MAIN UNIT

TOP VIEW

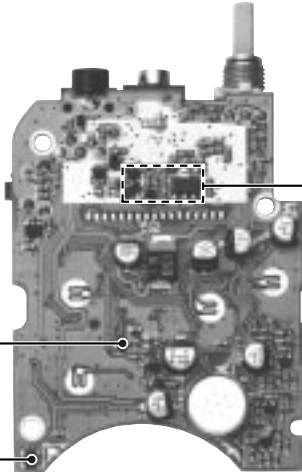

R+3 Current amplifier
(Q18: 2SA1586)

+3 Regulator
(IC6: S-81230SG)

AF amplifier
(IC9: NJM2070M)

T+3 Current amplifier
(Q27: 2SC4081
Q28: 2SB798
Q101: UMZ1N
D5: 1SS355)

BOTTOM VIEW



EEPROM
(IC3: AT24C02N)

CPU
(IC1: μ PD753036GK)

• RF UNIT

TOP VIEW

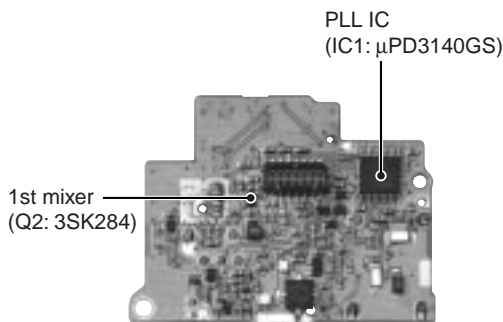

1st mixer
(Q2: 3SK284)

PLL IC
(IC1: μ PD3140GS)

BOTTOM VIEW

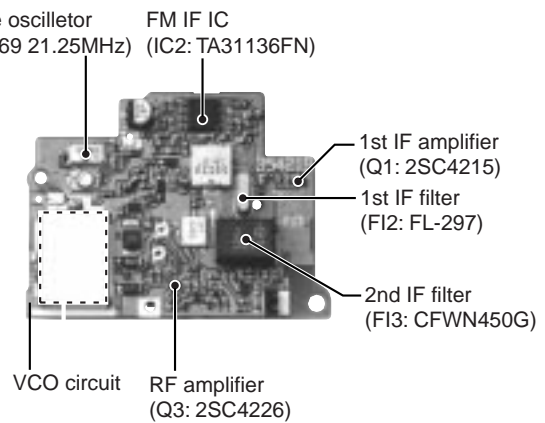

Reference oscillator
(X1: CR-669 21.25MHz)

FM IF IC
(IC2: TA31136FN)

1st IF amplifier
(Q1: 2SC4215)

1st IF filter
(F12: FL-297)

2nd IF filter
(F13: CFWN450G)

VCO circuit

RF amplifier
(Q3: 2SC4226)

SECTION 3 DISASSEMBLY INSTRUCTION

● REMOVING THE REAR PANEL

- ① Unscrew 1 screw (A), and 4 screws (B).
- ② Remove the rear panel in the direction of the arrow.

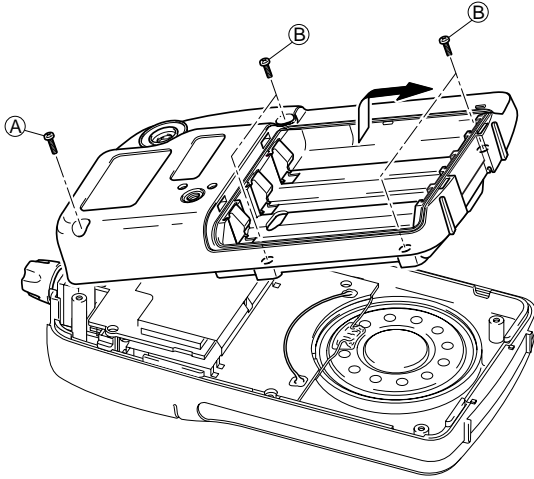

● REMOVING THE MAIN UNIT

- ① Unscrew 2 screws, (E).
- ② Remove the PTT rubber, (F).
- ③ Unsolder 2 points, (G), and remove the MAIN unit.

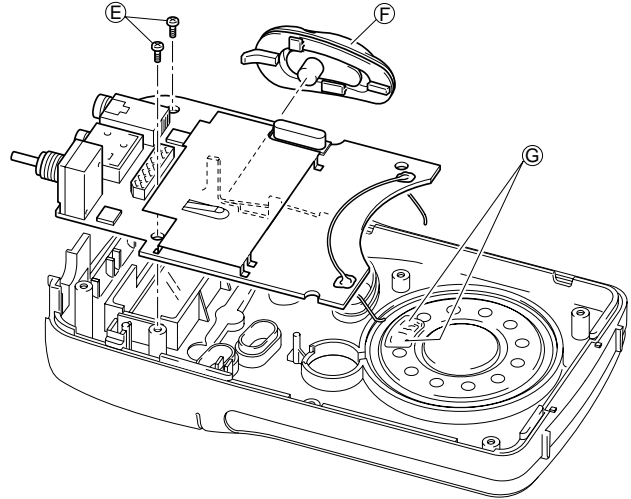

● REMOVING THE RF UNIT

- ① Remove 1 knob (C), and unscrew 1 nut (D).
- ② Then remove the RF unit.

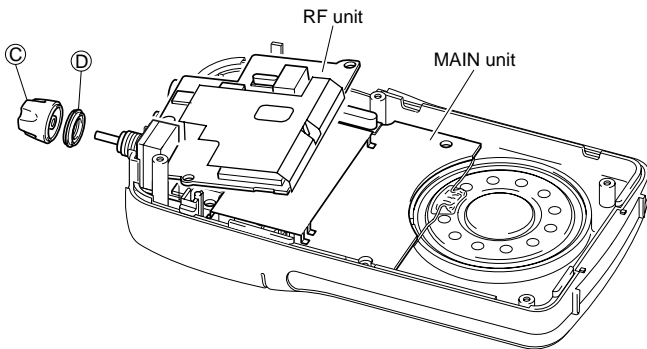

SECTION 4 CIRCUIT DESCRIPTION

4-1 RECEIVER CIRCUITS

4-1-1 ANTENNA SWITCHING CIRCUIT (RF UNIT)

Received signals from the antenna connector are passed through the low-pass filter (L5, L6, C8–C12). The filtered signals are applied to the $\lambda/4$ type antenna switching circuit (D101, D102, L4, L206, C209, C210). The passed signals are then applied to the RF amplifier circuit.

The antenna switching circuit functions as a low-pass filter while receiving. However, its impedance becomes very high while D101 and D102 are turned ON (while transmitting). Thus transmit signals are blocked from entering the receiver circuits. The passed signals are then applied to the RF amplifier circuit.

4-1-2 RF CIRCUIT (RF UNIT)

The RF circuit amplifies signals within the range of frequency coverage and filters out-of-band signals.

The signals from the antenna switching circuit are amplified at the RF amplifier (Q3) and passed through the bandpass filter (F11) to suppress out-of-band signals. The filtered signals are applied to the 1st mixer circuit.

4-1-3 1ST MIXER AND 1ST IF CIRCUITS (RF UNIT)

The 1st mixer circuit converts the received signals to a fixed frequency of the 1st IF signal with a PLL output frequency. By changing the PLL frequency, only desired signals will pass through a crystal filter at the next stage of the 1st mixer.

The signals from the bandpass filter (F11) are mixed at the 1st mixer circuit (Q2) with a 1st LO signal coming from the VCO circuit to produce a 21.7 MHz 1st IF signal.

The 1st IF signal is applied to a crystal filter (F12) to suppress out-of-band signals. The filtered 1st IF signal is applied to the IF amplifier (Q1), then applied to the 2nd mixer circuit.

4-1-4 2ND MIXER AND DEMODULATOR CIRCUITS (RF UNIT)

The 2nd mixer circuit converts the 1st IF signal into a 2nd IF signal. A double conversion superheterodyne system (which converts receive signals twice) improves the image rejection ratio and obtains stable receiver gain.

The 1st IF signal from the IF amplifier (Q1) is applied to the 2nd mixer section in the FM IF IC (IC2, pin 16), and is mixed with the 2nd LO signal to be converted into a 450 kHz 2nd IF signal.

The FM IF IC contains a 2nd mixer, quadrature detector, noise amplifier and a limiter amplifier, etc. The PLL reference oscillator (X1) is used for the 2nd LO signal via the PLL IC (IC1, pins 16, 17), and is applied to pin 1 of the FM IF IC (IC2).

The mixed 2nd IF signal is output from pin 3 (IC2) and passed through the ceramic bandpass filter (F13) to remove unwanted heterodyne frequencies. It is then amplified at the limiter amplifier section (IC2, pin 5) and applied to the quadrature detector section (IC2, pins 10, 11) to demodulate the 2nd IF signal into AF signals.

4-1-5 AF CIRCUIT (RF AND MAIN UNITS)

AF signals from the FM IF IC (RF unit; IC2, pin 9) are passed through the high-pass filter (RF unit; Q15, Q16) to remove CTCSS signals then applied to the MAIN unit via J2 (pin 10) as the "VOL" signal.

The "VOL" signal (AF signals) from the RF unit is applied to the [VOL] control (MAIN unit; R58) to control the audio level via the volume mute switch (Q23). The level controlled AF signals are applied to the AF power amplifier (IC9, pin 2) to drive an internal speaker (SP1) via the [SP] jack (J1).

• 2nd IF and demodulator circuits

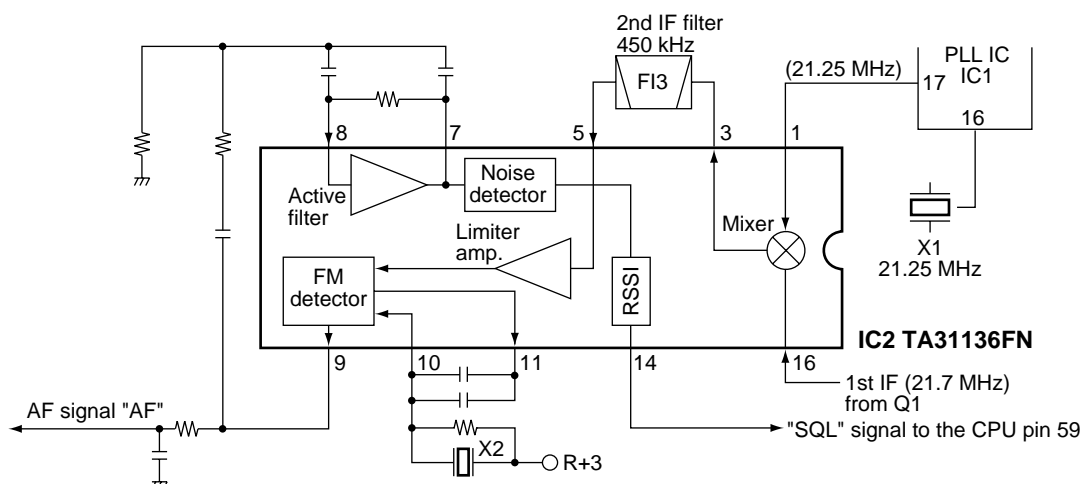

4-1-6 SQUELCH CIRCUIT (RF AND MAIN UNITS)

• NOISE SQUELCH

The noise squelch circuit cuts out AF signals when no RF signals are received. By detecting noise components in the AF signals, the squelch circuit switches the AF mute switch.

A portion of the AF signals from the FM IF IC (RF unit; IC2, pin 9) are applied to the active filter section (RF unit; IC2, pin 8). The active filter section amplifies and filters noise components. The filtered signals are applied to the noise detector section and output from pin 14 as the "SQL" signal.

The "SQL" signal from IC2 (pin14) is applied to the CPU (MAIN unit; IC1, pin 59). The CPU analyzes the noise condition and outputs the "RMUT" and "AFON" signals to toggle the volume mute (MAIN unit; Q23) and AF mute (MAIN unit; Q5, Q10, Q11) switches.

• TONE SQUELCH

The tone squelch circuit detects AF signals and opens the squelch only when receiving signal containing a matching subaudible tone (CTCSS). When tone squelch is in use, and a signal with a mismatched or no subaudible tone is received, the tone squelch circuit mutes the AF signals even when noise squelch is open.

A portion of the AF signals from the FM IF IC (RF unit; IC2, pin 9) passes through the tone low-pass filter (MAIN unit; Q7, Q12) to remove AF (voice) signals and is applied to the CTCSS decoder inside the CPU (MAIN unit; IC1, pin 58) via the "CTCIN" line to control the volume mute and AF mute switches.

4-2 TRANSMITTER CIRCUITS

4-2-1 MICROPHONE AMPLIFIER CIRCUIT (MAIN UNIT)

The microphone amplifier circuit amplifies audio signals with pre-emphasis characteristics from the microphone to a level needed for the modulation circuit.

AF signals from the internal/external microphone are applied to the microphone amplifier circuit (IC2b) via the microphone mute switch (Q6) and pre-emphasis circuit (R7, C24). The amplified signals are passed through the splatter filter (IC2a) and applied to the modulation circuit in the RF unit via J4 (pin 6) as the MOD signal.

• PLL circuit

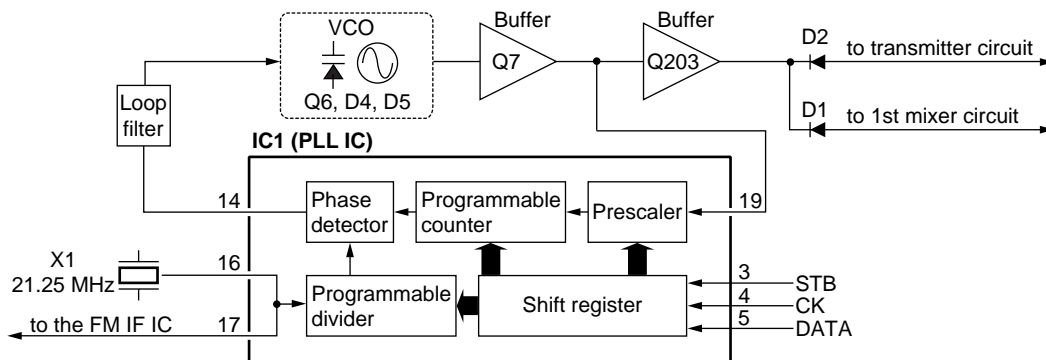

4-2-2 MODULATION CIRCUIT (RF UNIT)

The modulation circuit modulates the VCO oscillating signal (RF signal) using the microphone AF signals.

The filtered audio signals from the MAIN unit are passed through the deviation adjustment pot (R50), and are then applied to the modulation circuit (D4, D5) to modulate transmit signals at the VCO circuit (Q6).

The modulated signal is applied to the drive amplifier circuit.

4-2-3 DRIVE/POWER AMPLIFIER CIRCUITS (RF UNIT)

The amplifier circuit amplifies the VCO oscillating signal to the output power level.

The signal from the buffer amplifiers (Q7, Q203) is passed through the Tx/Rx switching circuit (D2), and are amplified at the pre-drive (Q8) and drive (Q201) amplifiers. The amplified signal is power-amplified at the power amplifier (Q202) to obtain 500 mW of RF power

The amplified transmit signal is passed through the antenna switching circuit (D7) and low-pass filter, and is then applied to the antenna.

4-3 PLL CIRCUITS (RF UNIT)

A PLL circuit provides stable oscillation of the transmit frequency and receive 1st LO frequency. The PLL output compares the phase of the divided VCO frequency to the reference frequency. The PLL output frequency is controlled by the divided ratio (N-data) of a programmable divider.

The PLL circuit consists of the VCO circuit (Q6). An oscillated signal from the VCO passes through the buffer amplifier (Q7), and is then applied to the PLL IC (IC1, pin19) and prescaled in the PLL IC based on the divided ratio (N-data).

The reference signal is generated at the reference oscillator (X1) and is applied to the PLL IC. The PLL IC detects the out-of-step phase using the reference frequency and outputs it from pin 13 (IC1). The output signal is passed through the loop filter (R45, C68) and is then applied to the VCO circuit as the lock voltage.

If the oscillated signal drifts, its phase changes from that of the reference frequency, causing a lock voltage change to compensate for the drift in the oscillated frequency.

4-4 POWER SUPPLY CIRCUITS

VOLTAGE LINE

LINE	DESCRIPTION
BATT	The voltage from the connected battery cells.
3V	Common 3 V converted from the BATT line at the 3V regulator circuit (IC6). The circuit outputs the voltage regardless of the power ON/OFF condition.
+3V	Common 3 V converted from the BATT line at the +3V regulator circuit (Q25, D4).
R+3	Receive 3 V controlled by the R+3 regulator circuit (Q18) using the "RXV" signal from CPU (IC1).
T+3	Transmit 3 V converted from the BATT line at the T+3 regulator circuit (Q27, Q28, Q101, D5) using the "TXV" signal coming from CPU (IC1).

4-5 PORT ALLOCATIONS

4-5-1 CPU (MAIN unit; IC1)

Pin number	Port name	Description
4	SHIFT	Outputs VCO oscillation frequency control signal for Tx/Rx. Low : While transmitting
31	PTT2	Input port for the PTT switch from the external mic jack (MAIN unit; J1). Low : External PTT switch is ON.
34	PTT1	Input port for the internal PTT switch. Low : While PTT switch is pushed.
35	DOWN	Input port for the [DOWN] switch.
36	UP	Input port for the [UP] switch.
37	MODE	Input port for the [MODE] switch.
38	POWSW	Input port for the POWER switch. Low : While POWER switch is pushed.
46	BEEP	Outputs beep audio signal.
48	RMUTE	Outputs volume mute switch (Q23) control signal. High : While squelched
49	AFON	Outputs control signal for the AF amplifier regulator circuit (Q5, Q10, Q11). High: When squelch is open.
50	PLLCK	Outputs clock signal to the PLL IC (RF unit; IC1).

Pin number	Port name	Description
51	PLLDA	Outputs data signals to the PLL IC (RF unit; IC1).
52	PLLST	Outputs strobe signals for the PLL IC (RF unit; IC1).
53	POWER	Outputs control signal for the +3V regulator circuit (MAIN unit; Q25, D4).
54–56	CTCO0–CTCO2	Output port for the CTCSS signals.
57	TXMOD	Outputs control signal for the microphone amplifier (IC2). Low : While microphone amplifier is ON.
58	CTCIN	Input port for the CTCSS decode signals.
59	SQLIN	Input port for squelch level signal.
60	REMIN	Input ports for the control signal from the external remote microphone.
61	BATIN	Input port from the connected battery pack for low battery indication.
62	SENIN	Input port for the RSSI signal from the FM IF IC (RF unit; IC2) to detect receiving signal strength level.
73	EEPCK	Outputs clock signal to the EEPROM (IC3).
74	EEPDA	Outputs data signals to the EEPROM (IC3).
75	PSC	Output port for power save function, applied to VCO regulator circuit (RF unit; Q13, Q14, D8, D9).
76	RXV	Outputs the R+3 regulator control signal (Q25, D4).
77	TXV	Outputs the T+3 regulator control signal (Q27, Q28, Q101, D5).
78	LAMPC	Outputs control signal for LCD backlight. Low : While LCD backlight is ON.
79	MICSW	Outputs internal microphone control signal. High : While internal PTT switch is pushed.
80	MMUTE	Outputs MIC mute signal for RING function. High : While RING signals are output, etc.

SECTION 5 ADJUSTMENT PROCEDURES

5-1 PREPARATION

■ REQUIRED TEST EQUIPMENT

EQUIPMENT	GRADE AND RANGE	EQUIPMENT	GRADE AND RANGE
DC power supply	Output voltage : 4.5 V DC Current capacity : 1 A or more	Audio generator	Frequency range : 300–3000 Hz Measuring range : 1–500 mV
Frequency counter	Frequency range : 0.1–600 MHz Frequency accuracy : ± 1 ppm or better Sensitivity : 100 mV or better	Standard signal generator (SSG)	Frequency range : 0.1–600 MHz Output level : 0.1 μ V–32 mV (–127 to –17 dBm)
FM deviation meter	Frequency range : 30–600 MHz Measuring range : 0 to ± 10 kHz	Oscilloscope	Frequency range : DC–20 MHz Measuring range : 0.01–10 V
DC voltmeter	Input impedance : 50 k Ω /V DC or better	AC millivoltmeter	Measuring range : 10 mV–10 V
RF power meter (terminated type)	Measuring range : 100 mW–1 W Frequency range : 300–600 MHz Impedance : 50 Ω SWR : Less than 1.2 : 1	External speaker	Input impedance : 8 Ω Capacity : 300 mW or more
		Attenuator	Power attenuation : 30 or 40 dB Capacity : 1 W or more

■ ENTERING THE ADJUSTMENT MODE

- ① Turn the transceiver power OFF.
- ② While connecting the “TEST” and GND on the MAIN unit, then turn power ON.
(See location at page 5-3)

■ CONNECTIONS

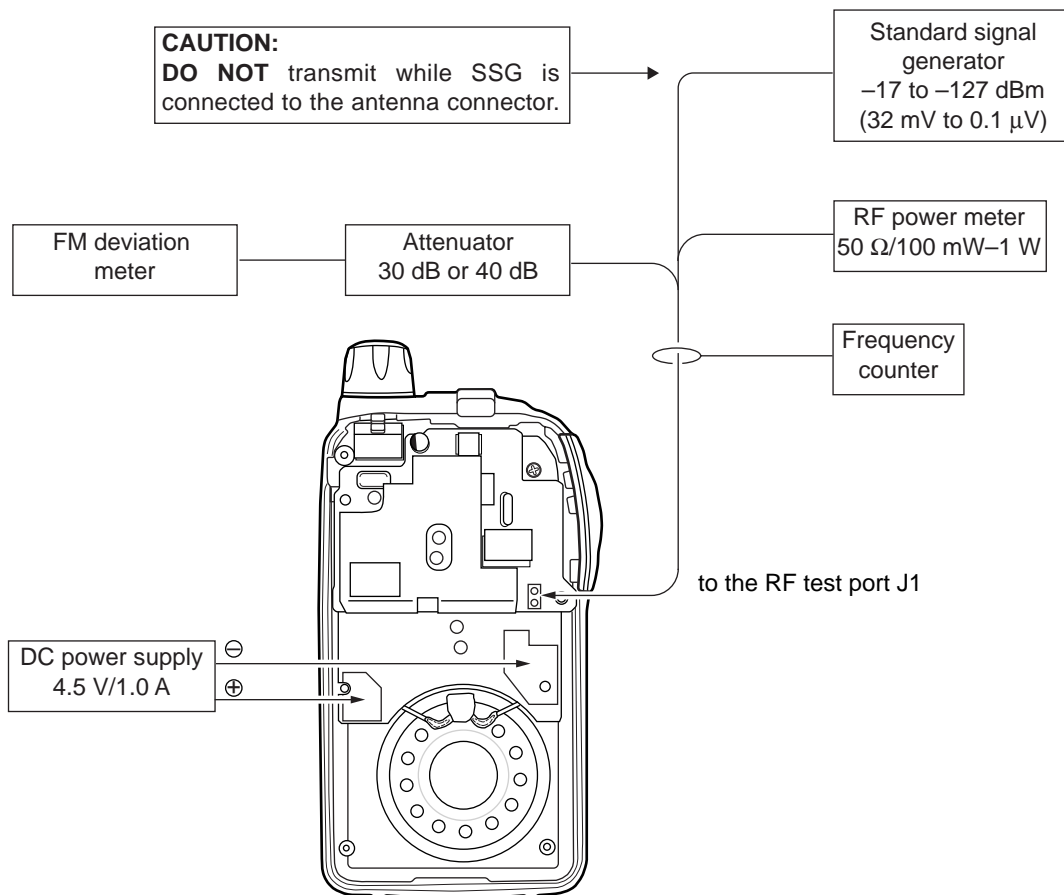

5-2 PLL AND TRANSMITTER ADJUSTMENTS

ADJUSTMENT	ADJUSTMENT CONDITION	MEASUREMENT		VALUE	ADJUSTMENT POINT	
		UNIT	LOCATION		UNIT	ADJUST
REFERENCE FREQUENCY	1 <ul style="list-style-type: none"> • Operating channel : Ch 01 • Transmitting 	Top panel	Loosely couple a frequency counter to the antenna.	466.00625 MHz	RF	C63
OUTPUT POWER	1 <ul style="list-style-type: none"> • Operating channel : Ch 01 • Transmitting 	RF	Connect an RF power meter to the RF test port J1.	470 mW	RF	R206
FM DEVIATION	1 <ul style="list-style-type: none"> • Operating channel : Ch 01 • Set group No. : 01 • Connect an audio generator to the [MIC] jack and set as: 1 kHz/100 mV rms • Set an FM deviation meter as: HPF : OFF LPF : 20 kHz or 15 kHz De-emphasis : OFF Detector : (P-P)/2 • Transmitting 	RF	Connect an FM deviation meter to the RF test port J1.	±2.45 kHz	RF	R50
	2 <ul style="list-style-type: none"> • Set group No. : OFF (—) • Set an audio generator output level until the deviation is ±1.75 kHz. • Transmitting 			10 mV ±3dB		

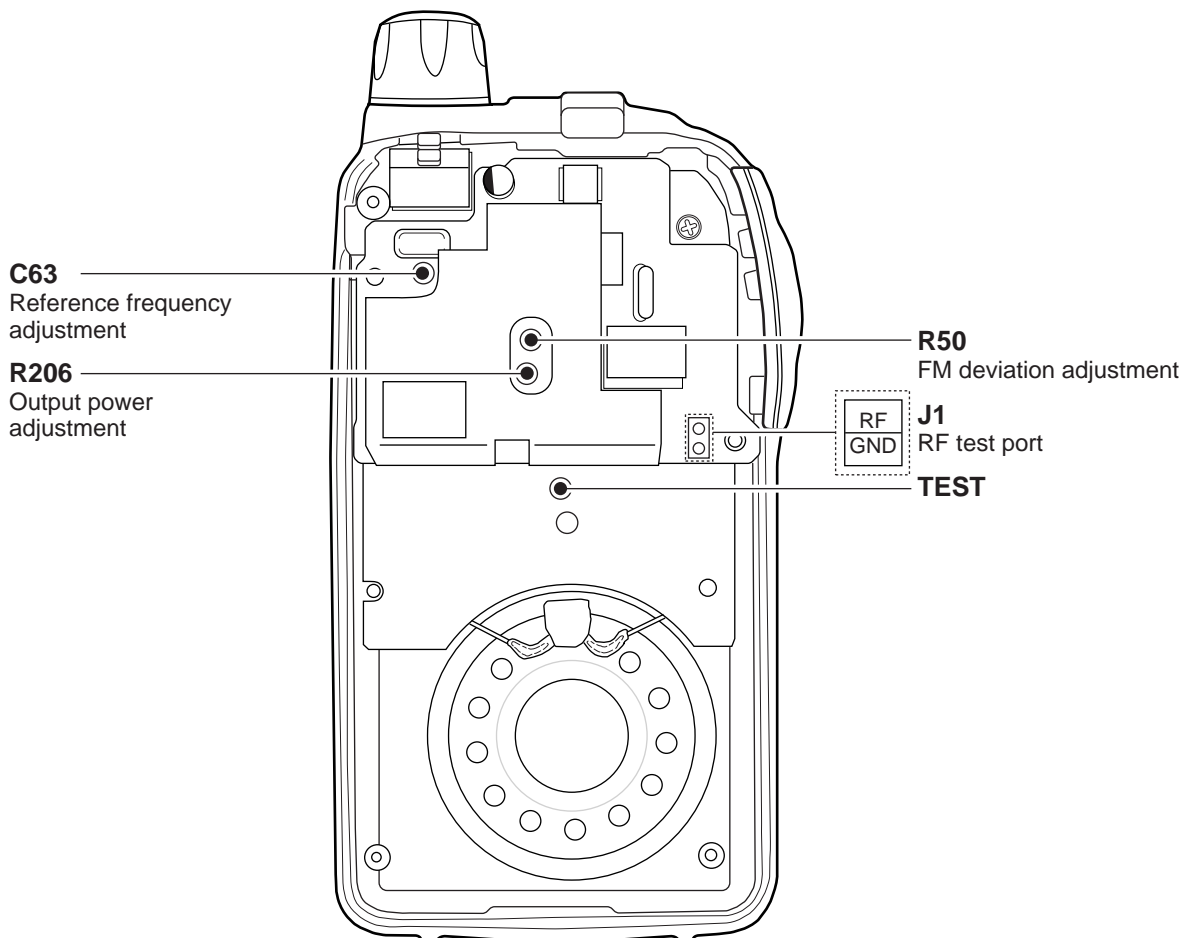

5-3 RECEIVER ADJUSTMENT

ADJUSTMENT	ADJUSTMENT CONDITION	MEASUREMENT		VALUE	ADJUSTMENT
		UNIT	LOCATION		
SQUELCH	1 <ul style="list-style-type: none"> • Operating channel : Ch 04 • Connect an SSG to J1 on the RF unit and set as: <ul style="list-style-type: none"> Frequency : 446.04375 MHz Level : 0.14 μV* (-124 dBm) Modulation : OFF • Receiving 	Front panel			Push and hold [MODE] and [DOWN] keys for 1 sec.
	2 <ul style="list-style-type: none"> • Set an SSG as : <ul style="list-style-type: none"> Level : OFF • Receiving 		Internal speaker	Audio signal disappears.	Verify

SECTION 6 PARTS LIST

[MAIN UNIT]

REF NO.	ORDER NO.	DESCRIPTION	
IC1	1140008770	S.IC	μPD753036GK-559-BE9
IC2	1110002820	S.IC	NJM2100M-T1
IC3	1140008350	S.IC	AT24C02N-10SI-2.7
IC5	1110004710	S.IC	S-80928ANMP-DDR-T2
IC6	1180001150	S.IC	S-81230SG-QB-T1
IC9	1110002810	S.IC	NJM2070M-T1
Q1	1590000720	S.TRANSISTOR	DTA144EUA T106
Q2	1590001440	S.TRANSISTOR	UN9214 (TX)
Q3	1590002920	S.TRANSISTOR	DTA123JUA T106
Q5	1510000580	S.TRANSISTOR	2SA1362-GR (TE85R)
Q6	1560000840	S.FET	2SK1829 (TE85R)
Q7	1530002280	S.TRANSISTOR	2SC4081 T107 S
Q10	1530002280	S.TRANSISTOR	2SC4081 T107 S
Q11	1530003090	S.TRANSISTOR	2SC4213-B (TE85R)
Q12	1530002280	S.TRANSISTOR	2SC4081 T107 S
Q14	1590001330	S.TRANSISTOR	DTA114EUA T106
Q18	1510000770	S.TRANSISTOR	2SA1586-GR (TE85R)
Q23	1590001390	S.FET	2SJ144-Y (TE85R)
Q25	1590002490	S.TRANSISTOR	UMZ2N TR
Q27	1530002280	S.TRANSISTOR	2SC4081 T107 S
Q28	1520000200	S.TRANSISTOR	2SB798-T2 DK
Q29	1590000680	S.TRANSISTOR	DTC114EUA T106
Q101	1590002630	S.TRANSISTOR	UMZ1N TR
D2	1750000550	S.DIODE	1SS355 TE-17
D4	1750000550	S.DIODE	1SS355 TE-17
D5	1750000550	S.DIODE	1SS355 TE-17
X1	6050010450	S.XTAL	CR-627 (5.8368 MHz)
R2	7030003670	S.RESISTOR	ERJ3GEYJ 823 V (82 kΩ)
R4	7030003670	S.RESISTOR	ERJ3GEYJ 823 V (82 kΩ)
R5	7030003810	S.RESISTOR	ERJ3GEYJ 125 V (1.2 MΩ)
R6	7030003710	S.RESISTOR	ERJ3GEYJ 184 V (180 kΩ)
R7	7030003450	S.RESISTOR	ERJ3GEYJ 122 V (1.2 kΩ)
R9	7030003680	S.RESISTOR	ERJ3GEYJ 104 V (100 kΩ)
R10	7030003310	S.RESISTOR	ERJ3GEYJ 820 V (82 Ω)
R12	7030003200	S.RESISTOR	ERJ3GEYJ 100 V (10 Ω)
R13	7030003520	S.RESISTOR	ERJ3GEYJ 472 V (4.7 kΩ)
R14	7030003500	S.RESISTOR	ERJ3GEYJ 332 V (3.3 kΩ)
R22	7030003620	S.RESISTOR	ERJ3GEYJ 333 V (33 kΩ)
R23	7030003580	S.RESISTOR	ERJ3GEYJ 153 V (15 kΩ)
R24	7030003820	S.RESISTOR	ERJ3GEYJ 155 V (1.5 MΩ)
R25	7030003570	S.RESISTOR	ERJ3GEYJ 123 V (12 kΩ)
R26	7030003560	S.RESISTOR	ERJ3GEYJ 103 V (10 kΩ)
R27	7030003320	S.RESISTOR	ERJ3GEYJ 101 V (100 Ω)
R30	7030003580	S.RESISTOR	ERJ3GEYJ 153 V (15 kΩ)
R31	7030003800	S.RESISTOR	ERJ3GEYJ 105 V (1 MΩ)
R32	7030003780	S.RESISTOR	ERJ3GEYJ 684 V (680 kΩ)
R33	7030003540	S.RESISTOR	ERJ3GEYJ 682 V (6.8 kΩ)
R34	7030003540	S.RESISTOR	ERJ3GEYJ 682 V (6.8 kΩ)
R35	7030003530	S.RESISTOR	ERJ3GEYJ 562 V (5.6 kΩ)
R36	7030003560	S.RESISTOR	ERJ3GEYJ 103 V (10 kΩ)
R37	7030003600	S.RESISTOR	ERJ3GEYJ 223 V (22 kΩ)
R38	7030003600	S.RESISTOR	ERJ3GEYJ 223 V (22 kΩ)
R39	7030003670	S.RESISTOR	ERJ3GEYJ 823 V (82 kΩ)
R40	7030003680	S.RESISTOR	ERJ3GEYJ 104 V (100 kΩ)
R41	7030003530	S.RESISTOR	ERJ3GEYJ 562 V (5.6 kΩ)
R42	7030003500	S.RESISTOR	ERJ3GEYJ 332 V (3.3 kΩ)
R43	7030003650	S.RESISTOR	ERJ3GEYJ 563 V (56 kΩ)
R45	7030003840	S.RESISTOR	ERJ3GEYJ 225 V (2.2 MΩ)
R46	7030003320	S.RESISTOR	ERJ3GEYJ 101 V (100 Ω)
R49	7030003320	S.RESISTOR	ERJ3GEYJ 101 V (100 Ω)
R50	7030003520	S.RESISTOR	ERJ3GEYJ 472 V (4.7 kΩ)
R51	7030003760	S.RESISTOR	ERJ3GEYJ 474 V (470 kΩ)
R52	7030003740	S.RESISTOR	ERJ3GEYJ 334 V (330 kΩ)
R53	7030003820	S.RESISTOR	ERJ3GEYJ 155 V (1.5 MΩ)
R54	7030003450	S.RESISTOR	ERJ3GEYJ 122 V (1.2 kΩ)
R55	7030003330	S.RESISTOR	ERJ3GEYJ 121 V (120 Ω)
R56	7030004050	S.RESISTOR	ERJ3GEYJ 1R0 V (1 Ω)
R57	7030003580	S.RESISTOR	ERJ3GEYJ 153 V (15 kΩ)

[MAIN UNIT]

REF NO.	ORDER NO.	DESCRIPTION	
R58	7210001970	VARIABLE	RV-244
R59	7030003680	S.RESISTOR	ERJ3GEYJ 104 V (100 kΩ)
R61	7030003280	S.RESISTOR	ERJ3GEYJ 470 V (47 Ω)
R62	7030003680	S.RESISTOR	ERJ3GEYJ 104 V (100 kΩ)
R63	7030003530	S.RESISTOR	ERJ3GEYJ 562 V (5.6 kΩ)
R64	7030003590	S.RESISTOR	ERJ3GEYJ 183 V (18 kΩ)
R65	7030003590	S.RESISTOR	ERJ3GEYJ 183 V (18 kΩ)
R66	7030003590	S.RESISTOR	ERJ3GEYJ 183 V (18 kΩ)
R67	7030003590	S.RESISTOR	ERJ3GEYJ 183 V (18 kΩ)
R68	7030003590	S.RESISTOR	ERJ3GEYJ 183 V (18 kΩ)
R69	7030003590	S.RESISTOR	ERJ3GEYJ 183 V (18 kΩ)
R70	7030003660	S.RESISTOR	ERJ3GEYJ 683 V (68 kΩ)
R71	7030003620	S.RESISTOR	ERJ3GEYJ 333 V (33 kΩ)
R72	7030003800	S.RESISTOR	ERJ3GEYJ 105 V (1 MΩ)
R74	7030003560	S.RESISTOR	ERJ3GEYJ 103 V (10 kΩ)
R76	7030003680	S.RESISTOR	ERJ3GEYJ 104 V (100 kΩ)
R77	7030003400	S.RESISTOR	ERJ3GEYJ 471 V (470 Ω)
R78	7030003560	S.RESISTOR	ERJ3GEYJ 103 V (10 kΩ)
R79	7030003720	S.RESISTOR	ERJ3GEYJ 224 V (220 kΩ)
R80	7030003680	S.RESISTOR	ERJ3GEYJ 104 V (100 kΩ)
R81	7030003560	S.RESISTOR	ERJ3GEYJ 103 V (10 kΩ)
R86	7030003680	S.RESISTOR	ERJ3GEYJ 104 V (100 kΩ)
R87	7030003800	S.RESISTOR	ERJ3GEYJ 105 V (1 MΩ)
R88	7030003680	S.RESISTOR	ERJ3GEYJ 104 V (100 kΩ)
R89	7030003440	S.RESISTOR	ERJ3GEYJ 102 V (1 kΩ)
R90	7030003440	S.RESISTOR	ERJ3GEYJ 102 V (1 kΩ)
R94	7030003720	S.RESISTOR	ERJ3GEYJ 224 V (220 kΩ)
R95	7030003520	S.RESISTOR	ERJ3GEYJ 472 V (4.7 kΩ)
R96	7030003680	S.RESISTOR	ERJ3GEYJ 104 V (100 kΩ)
R97	7030003680	S.RESISTOR	ERJ3GEYJ 104 V (100 kΩ)
R98	7030003680	S.RESISTOR	ERJ3GEYJ 104 V (100 kΩ)
R99	7030003680	S.RESISTOR	ERJ3GEYJ 104 V (100 kΩ)
R100	7030003680	S.RESISTOR	ERJ3GEYJ 104 V (100 kΩ)
R101	7030003680	S.RESISTOR	ERJ3GEYJ 104 V (100 kΩ)
R102	7030003680	S.RESISTOR	ERJ3GEYJ 104 V (100 kΩ)
R103	7030003680	S.RESISTOR	ERJ3GEYJ 104 V (100 kΩ)
R105	7030003560	S.RESISTOR	ERJ3GEYJ 103 V (10 kΩ)
R106	7030003560	S.RESISTOR	ERJ3GEYJ 103 V (10 kΩ)
R108	7030003620	S.RESISTOR	ERJ3GEYJ 333 V (33 kΩ)
R110	7030003800	S.RESISTOR	ERJ3GEYJ 105 V (1 MΩ)
R112	7030003560	S.RESISTOR	ERJ3GEYJ 103 V (10 kΩ)
R114	7030003500	S.RESISTOR	ERJ3GEYJ 332 V (3.3 kΩ)
R115	7030003410	S.RESISTOR	ERJ3GEYJ 561 V (560 Ω)
R117	7030003680	S.RESISTOR	ERJ3GEYJ 104 V (100 kΩ)
R118	7030003520	S.RESISTOR	ERJ3GEYJ 472 V (4.7 kΩ)
R119	7030003680	S.RESISTOR	ERJ3GEYJ 104 V (100 kΩ)
R200	7030003840	S.RESISTOR	ERJ3GEYJ 225 V (2.2 MΩ)
R201	7030003370	S.RESISTOR	ERJ3GEYJ 271 V (270 Ω)
R202	7030003320	S.RESISTOR	ERJ3GEYJ 101 V (100 Ω)
R203	7030003550	S.RESISTOR	ERJ3GEYJ 822 V (8.2 kΩ)
R204	7030003540	S.RESISTOR	ERJ3GEYJ 682 V (6.8 kΩ)
C1	4030008470	S.CERAMIC	C1608 JB 1H 272K-T-A
C3	4030011600	S.CERAMIC	C1608 JB 1C 104KT-N
C4	4030011600	S.CERAMIC	C1608 JB 1C 104KT-N
C5	4030006850	S.CERAMIC	C1608 JB 1H 471K-T-A
C6	4030008680	S.CERAMIC	C2012 JF 1C 105Z-T-A
C7	4030011600	S.CERAMIC	C1608 JB 1C 104KT-N
C8	4510004630	S.ELECTROLYTIC	ECEV1CA100SR
C9	4030006850	S.CERAMIC	C1608 JB 1H 471K-T-A
C10	4030006850	S.CERAMIC	C1608 JB 1H 471K-T-A
C11	4030006850	S.CERAMIC	C1608 JB 1H 471K-T-A
C15	4030011600	S.CERAMIC	C1608 JB 1C 104KT-N
C17	4550006880	S.TANTALUM	TEMSVD2 0J 157M-12R
C18	4510004630	S.ELECTROLYTIC	ECEV1CA100SR
C20	4030011600	S.CERAMIC	C1608 JB 1C 104KT-N
C21	4030011600	S.CERAMIC	C1608 JB 1C 104KT-N
C24	4030008900	S.CERAMIC	C1608 JB 1C 333K-T-A
C25	4030006850	S.CERAMIC	C1608 JB 1H 471K-T-A
C26	4030006850	S.CERAMIC	C1608 JB 1H 471K-T-A
C27	4030011600	S.CERAMIC	C1608 JB 1C 104KT-N
C28	4030008920	S.CERAMIC	C1608 JB 1C 473K-T-A
C29	4030007150	S.CERAMIC	C1608 CH 1H 151J-T-A
C31	4030008880	S.CERAMIC	C1608 JB 1C 223K-T-A
C32	4030011600	S.CERAMIC	C1608 JB 1C 104KT-N

S.=Surface mount

[MAIN UNIT]

REF NO.	ORDER NO.	DESCRIPTION	
C34	4030006880	S.CERAMIC	C1608 JB 1H 472K-T-A
C35	4030011600	S.CERAMIC	C1608 JB 1C 104KT-N
C36	4030006860	S.CERAMIC	C1608 JB 1H 102K-T-A
C40	4030011600	S.CERAMIC	C1608 JB 1C 104KT-N
C42	4030006900	S.CERAMIC	C1608 JB 1E 103K-T-A
C44	4030011600	S.CERAMIC	C1608 JB 1C 104KT-N
C45	4030009650	S.CERAMIC	C1608 CH 1H 240J-T-A
C46	4030009650	S.CERAMIC	C1608 CH 1H 240J-T-A
C47	4030006850	S.CERAMIC	C1608 JB 1H 471K-T-A
C48	4510005430	S.ELECTROLYTIC	ECEV0JA220SR
C49	4030011600	S.CERAMIC	C1608 JB 1C 104KT-N
C50	4030011600	S.CERAMIC	C1608 JB 1C 104KT-N
C51	4030011600	S.CERAMIC	C1608 JB 1C 104KT-N
C52	4510005860	S.ELECTROLYTIC	ECEV1HA2R2SR
C53	4030011600	S.CERAMIC	C1608 JB 1C 104KT-N
C54	4030011600	S.CERAMIC	C1608 JB 1C 104KT-N
C55	4510005870	S.ELECTROLYTIC	ECEV1HA3R3SR
C56	4030011600	S.CERAMIC	C1608 JB 1C 104KT-N
C57	4030011600	S.CERAMIC	C1608 JB 1C 104KT-N
C59	4030006850	S.CERAMIC	C1608 JB 1H 471K-T-A
C60	4030011600	S.CERAMIC	C1608 JB 1C 104KT-N
C61	4030011600	S.CERAMIC	C1608 JB 1C 104KT-N
C62	4030011600	S.CERAMIC	C1608 JB 1C 104KT-N
C63	4030011600	S.CERAMIC	C1608 JB 1C 104KT-N
C64	4510005430	S.ELECTROLYTIC	ECEV0JA220SR
C65	4030011600	S.CERAMIC	C1608 JB 1C 104KT-N
C67	4030009590	S.CERAMIC	C2012 JF 1C 225Z-T-A
C71	4030011600	S.CERAMIC	C1608 JB 1C 104KT-N
C72	4030006900	S.CERAMIC	C1608 JB 1E 103K-T-A
C73	4030008650	S.CERAMIC	C1608 JB 1H 332K-T-A
C74	4030006860	S.CERAMIC	C1608 JB 1H 102K-T-A
C75	4030006860	S.CERAMIC	C1608 JB 1H 102K-T-A
C79	4030011600	S.CERAMIC	C1608 JB 1C 104KT-N
C80	4510005900	S.ELECTROLYTIC	ECEV0GA101SR
C81	4030008900	S.CERAMIC	C1608 JB 1C 333K-T-A
C82	4030008920	S.CERAMIC	C1608 JB 1C 473K-T-A
C83	4030011600	S.CERAMIC	C1608 JB 1C 104KT-N
C85	4030011600	S.CERAMIC	C1608 JB 1C 104KT-N
C86	4030008960	S.CERAMIC	C2012 JB 1C 104K-T-A
C87	4030006850	S.CERAMIC	C1608 JB 1H 471K-T-A
C88	4030006850	S.CERAMIC	C1608 JB 1H 471K-T-A
C89	4030006850	S.CERAMIC	C1608 JB 1H 471K-T-A
C90	4030006850	S.CERAMIC	C1608 JB 1H 471K-T-A
C91	4030006850	S.CERAMIC	C1608 JB 1H 471K-T-A
C92	4030006850	S.CERAMIC	C1608 JB 1H 471K-T-A
C93	4030010760	S.CERAMIC	C1608 CH 1H 331J-T-A
C94	4030010760	S.CERAMIC	C1608 CH 1H 331J-T-A
C95	4030010760	S.CERAMIC	C1608 CH 1H 331J-T-A
C96	4030010760	S.CERAMIC	C1608 CH 1H 331J-T-A
C97	4030010760	S.CERAMIC	C1608 CH 1H 331J-T-A
C98	4030010760	S.CERAMIC	C1608 CH 1H 331J-T-A
C99	4030008650	S.CERAMIC	C1608 JB 1H 332K-T-A
J1	6450001130	CONNECTOR	HSJ1102-01-540
J3	6450001060	CONNECTOR	HSJ1493-01-010
J4	6510017950	S.CONNECTOR	4-175638-4
DS1	5010000120	S.LED	LN1371G-(TR)
DS2	5030001750	LCD	LD-BU10503J
MC1	7700002160	MICROPHON	KUC3523-040245
S1	2260001900	SWITCH	SW-149
W2	7030003860	S.JUMPER	ERJ3GE JPW V
W3	7030003860	S.JUMPER	ERJ3GE JPW V
W7	7030003860	S.JUMPER	ERJ3GE JPW V
EP1	8930045510	LCD CONTACT	SRCN-2045-SP-N-W
EP2	0910051962	PCB	B 5420B

[RF UNIT]

REF NO.	ORDER NO.	DESCRIPTION	
IC1	1130007610	S.IC	μPD3140GS-E1 (DS8)
IC2	1110003200	S.IC	TA31136FN (EL)
Q1	1530002600	S.TRANSISTOR	2SC4215-O (TE85R)
Q2	1580000670	S.FET	3SK284 (TE85R)
Q3	1530002920	S.TRANSISTOR	2SC4226-T2 R25
Q6	1530003320	S.TRANSISTOR	2SC5108-Y (TE85R)
Q7	1530003320	S.TRANSISTOR	2SC5108-Y (TE85R)
Q8	1530002940	S.TRANSISTOR	2SC4228-T2 R44
Q12	1530003260	S.TRANSISTOR	2SC5006-T1
Q13	1530002280	S.TRANSISTOR	2SC4081 T107 S
Q14	1510000770	S.TRANSISTOR	2SA1586-GR (TE85R)
Q15	1530002280	S.TRANSISTOR	2SC4081 T107 S
Q16	1530002280	S.TRANSISTOR	2SC4081 T107 S
Q201	1530000372	S.TRANSISTOR	2SC3356 R24-T2B
Q202	1590002890	S.FET	XRF9482T1
Q203	1530003320	S.TRANSISTOR	2SC5108-Y (TE85R)
D1	1790000620	S.DIODE	MA77 (TX)
D2	1790000620	S.DIODE	MA77 (TX)
D4	1720000640	S.VARICAP	1SV284 (TPH3)
D5	1720000640	S.VARICAP	1SV284 (TPH3)
D7	1790001260	S.DIODE	MA2S077-(TX)
D8	1750000550	S.DIODE	1SS355 TE-17
D9	1750000550	S.DIODE	1SS355 TE-17
D101	1790001260	S.DIODE	MA2S077-(TX)
D102	1790001260	S.DIODE	MA2S077-(TX)
D103	1790001240	S.DIODE	MA2S728-(TX)
FI1	2040001580	S.SAW	NSVS647
FI2	2010002320	MONOLITH	FL-297 (21.700 MHz)
FI3	2020001410	CERAMIC	CFWM450G
X1	6050010900	S.XTAL	CR-669 (21.2500 MHz)
X2	6070000210	S.DISCRIMINATOR	CDBCA450CX24
L1	6200003280	S.COIL	NL 252018T-2R2J
L3	6200007570	S.COIL	LL1608-FH18NJ
L4	6200005670	S.COIL	ELJRE 12NG-F
L5	6200008270	S.COIL	0.26-1.0-5TL 17N
L6	6200008270	S.COIL	0.26-1.0-5TL 17N
L10	6200005700	S.COIL	ELJRE 22NG-F
L11	6200003640	S.COIL	MLF1608K 100K-T
L12	6200003640	S.COIL	MLF1608K 100K-T
L13	6200002350	S.COIL	LQN 1A 27NJ04
L14	6200005720	S.COIL	ELJRE 33NG-F
L15	6200007000	S.COIL	ELJRE 82NG-F
L21	6200007580	S.COIL	LL1608-FH22NJ
L23	6200008430	S.COIL	0.20-1.0-4TL 15N
L25	6200002190	S.COIL	MLF2012A 4R7K-T
L201	6200007580	S.COIL	LL1608-FH22NJ
L202	6200005720	S.COIL	ELJRE 33NG-F
L203	6200007730	S.COIL	LQN21A 39NJ04
L204	6200008440	S.COIL	LQN21A 8N2D04
L205	6200006670	S.COIL	ELJRE 68NG-F
L206	6200005690	S.COIL	ELJRE 18NG-F
L208	6200003640	S.COIL	MLF1608K 100K-T
L209	6200006980	S.COIL	ELJRE R10G-F
L210	6200007600	S.COIL	LL1608-FH33NJ
L211	6200007590	S.COIL	LL1608-FH27NJ
R1	7030003430	S.RESISTOR	ERJ3GEYJ 821 V (820 Ω)
R2	7030003670	S.RESISTOR	ERJ3GEYJ 823 V (82 kΩ)
R3	7030003440	S.RESISTOR	ERJ3GEYJ 102 V (1 kΩ)
R4	7030003410	S.RESISTOR	ERJ3GEYJ 561 V (560 Ω)
R6	7030003520	S.RESISTOR	ERJ3GEYJ 472 V (4.7 kΩ)
R7	7030003280	S.RESISTOR	ERJ3GEYJ 470 V (47 Ω)
R10	7030003550	S.RESISTOR	ERJ3GEYJ 822 V (8.2 kΩ)
R12	7030003440	S.RESISTOR	ERJ3GEYJ 102 V (1 kΩ)
R16	7030003260	S.RESISTOR	ERJ3GEYJ 330 V (33 Ω)
R19	7030003380	S.RESISTOR	ERJ3GEYJ 331 V (330 Ω)
R25	7030003620	S.RESISTOR	ERJ3GEYJ 333 V (33 kΩ)
R27	7030003680	S.RESISTOR	ERJ3GEYJ 104 V (100 kΩ)
R29	7030003280	S.RESISTOR	ERJ3GEYJ 470 V (47 Ω)
R30	7030003620	S.RESISTOR	ERJ3GEYJ 333 V (33 kΩ)
R31	7030003620	S.RESISTOR	ERJ3GEYJ 333 V (33 kΩ)

S.=Surface mount

[RF UNIT]

REF NO.	ORDER NO.	DESCRIPTION	
R33	7030003550	S.RESISTOR	ERJ3GEYJ 822 V (8.2 kΩ)
R34	7030003420	S.RESISTOR	ERJ3GEYJ 681 V (680 Ω)
R35	7030003640	S.RESISTOR	ERJ3GEYJ 473 V (47 kΩ)
R36	7030003360	S.RESISTOR	ERJ3GEYJ 221 V (220 Ω)
R37	7030003600	S.RESISTOR	ERJ3GEYJ 223 V (22 kΩ)
R45	7030003550	S.RESISTOR	ERJ3GEYJ 822 V (8.2 kΩ)
R50	7310003630	S.TRIMMER	EVM-1XSX50 BQ4 (473)
R51	7030003770	S.RESISTOR	ERJ3GEYJ 564 V (560 kΩ)
R52	7030003460	S.RESISTOR	ERJ3GEYJ 152 V (1.5 kΩ)
R53	7030003700	S.RESISTOR	ERJ3GEYJ 154 V (150 kΩ)
R54	7030003560	S.RESISTOR	ERJ3GEYJ 103 V (10 kΩ)
R55	7030003580	S.RESISTOR	ERJ3GEYJ 153 V (15 kΩ)
R56	7030003580	S.RESISTOR	ERJ3GEYJ 153 V (15 kΩ)
R57	7030003480	S.RESISTOR	ERJ3GEYJ 222 V (2.2 kΩ)
R58	7030003520	S.RESISTOR	ERJ3GEYJ 472 V (4.7 kΩ)
R59	7030003580	S.RESISTOR	ERJ3GEYJ 153 V (15 kΩ)
R60	7030003680	S.RESISTOR	ERJ3GEYJ 104 V (100 kΩ)
R61	7030003560	S.RESISTOR	ERJ3GEYJ 103 V (10 kΩ)
R62	7030003230	S.RESISTOR	ERJ3GEYJ 180 V (18 Ω)
R64	7030003650	S.RESISTOR	ERJ3GEYJ 563 V (56 kΩ)
R65	7030003500	S.RESISTOR	ERJ3GEYJ 332 V (3.3 kΩ)
R66	7030003570	S.RESISTOR	ERJ3GEYJ 123 V (12 kΩ)
R67	7030003780	S.RESISTOR	ERJ3GEYJ 684 V (680 kΩ)
R68	7030003750	S.RESISTOR	ERJ3GEYJ 394 V (390 kΩ)
R69	7030003510	S.RESISTOR	ERJ3GEYJ 392 V (3.9 kΩ)
R70	7030003610	S.RESISTOR	ERJ3GEYJ 273 V (27 kΩ)
R71	7030003560	S.RESISTOR	ERJ3GEYJ 103 V (10 kΩ)
R72	7030003550	S.RESISTOR	ERJ3GEYJ 822 V (8.2 kΩ)
R73	7030003780	S.RESISTOR	ERJ3GEYJ 684 V (680 kΩ)
R74	7030003750	S.RESISTOR	ERJ3GEYJ 394 V (390 kΩ)
R75	7030003560	S.RESISTOR	ERJ3GEYJ 103 V (10 kΩ)
R76	7030003510	S.RESISTOR	ERJ3GEYJ 392 V (3.9 kΩ)
R83	7030003560	S.RESISTOR	ERJ3GEYJ 103 V (10 kΩ)
R86	7030003300	S.RESISTOR	ERJ3GEYJ 680 V (68 Ω)
R88	7030003520	S.RESISTOR	ERJ3GEYJ 472 V (4.7 kΩ)
R93	7030003200	S.RESISTOR	ERJ3GEYJ 100 V (10 Ω)
R202	7030003600	S.RESISTOR	ERJ3GEYJ 223 V (22 kΩ)
R205	7030003560	S.RESISTOR	ERJ3GEYJ 103 V (10 kΩ)
R206	7310003610	S.TRIMMER	EVM-1XSX50 B14 (103)
R207	7030003440	S.RESISTOR	ERJ3GEYJ 102 V (1 kΩ)
R208	7030003440	S.RESISTOR	ERJ3GEYJ 102 V (1 kΩ)
R209	7030003360	S.RESISTOR	ERJ3GEYJ 221 V (220 Ω)
R213	7030003360	S.RESISTOR	ERJ3GEYJ 221 V (220 Ω)
R301	7030003550	S.RESISTOR	ERJ3GEYJ 822 V (8.2 kΩ)
R302	7030003560	S.RESISTOR	ERJ3GEYJ 103 V (10 kΩ)
R303	7030003640	S.RESISTOR	ERJ3GEYJ 473 V (47 kΩ)
R304	7030003370	S.RESISTOR	ERJ3GEYJ 271 V (270 Ω)
R305	7030003510	S.RESISTOR	ERJ3GEYJ 392 V (3.9 kΩ)
R306	7030003550	S.RESISTOR	ERJ3GEYJ 822 V (8.2 kΩ)
R310	7030003740	S.RESISTOR	ERJ3GEYJ 334 V (330 kΩ)
R311	7030003400	S.RESISTOR	ERJ3GEYJ 471 V (470 Ω)
R312	7030003670	S.RESISTOR	ERJ3GEYJ 823 V (82 kΩ)
R313	7030003200	S.RESISTOR	ERJ3GEYJ 100 V (10 Ω)
C1	4030006860	S.CERAMIC	C1608 JB 1H 102K-T-A
C2	4030008920	S.CERAMIC	C1608 JB 1C 473K-T-A
C3	4030008920	S.CERAMIC	C1608 JB 1C 473K-T-A
C5	4030006850	S.CERAMIC	C1608 JB 1H 471K-T-A
C6	4030006850	S.CERAMIC	C1608 JB 1H 471K-T-A
C7	4030007050	S.CERAMIC	C1608 CH 1H 220J-T-A
C8	4030006970	S.CERAMIC	C1608 CH 1H 060D-T-A
C9	4030010780	S.CERAMIC	C1608 CH 1H 1R5C-T-A
C10	4030007010	S.CERAMIC	C1608 CH 1H 100D-T-A
C11	4030009470	S.CERAMIC	C1608 CH 1H R75C-T-A
C12	4030006990	S.CERAMIC	C1608 CH 1H 080D-T-A
C13	4030007090	S.CERAMIC	C1608 CH 1H 470J-T-A
C16	4030006850	S.CERAMIC	C1608 JB 1H 471K-T-A
C17	4340000180	S.MYLAR	ECHU 1C 333JB5
C20	4030006850	S.CERAMIC	C1608 JB 1H 471K-T-A
C21	4030006850	S.CERAMIC	C1608 JB 1H 471K-T-A
C23	4030006980	S.CERAMIC	C1608 CH 1H 070D-T-A
C26	4030006850	S.CERAMIC	C1608 JB 1H 471K-T-A
C28	4030006850	S.CERAMIC	C1608 JB 1H 471K-T-A
C30	4030006980	S.CERAMIC	C1608 CH 1H 070D-T-A
C31	4030006980	S.CERAMIC	C1608 CH 1H 070D-T-A
C32	4030006970	S.CERAMIC	C1608 CH 1H 060D-T-A
C35	4030006860	S.CERAMIC	C1608 JB 1H 102K-T-A
C36	4030006990	S.CERAMIC	C1608 CH 1H 080D-T-A
C42	4030007010	S.CERAMIC	C1608 CH 1H 100D-T-A
C43	4030007040	S.CERAMIC	C1608 CH 1H 180J-T-A
C44	4030007060	S.CERAMIC	C1608 CH 1H 270J-T-A

[RF UNIT]

REF NO.	ORDER NO.	DESCRIPTION	
C46	4030007020	S.CERAMIC	C1608 CH 1H 120J-T-A
C47	4030007050	S.CERAMIC	C1608 CH 1H 220J-T-A
C48	4030007050	S.CERAMIC	C1608 CH 1H 220J-T-A
C50	4030007020	S.CERAMIC	C1608 CH 1H 120J-T-A
C51	4030007020	S.CERAMIC	C1608 CH 1H 120J-T-A
C52	4030006930	S.CERAMIC	C1608 CH 1H 020C-T-A
C53	4030009540	S.CERAMIC	C1608 CH 1H 1R5B-T-A
C54	4030009350	S.CERAMIC	C1608 CH 1H 3R5B-T-A
C55	4030006850	S.CERAMIC	C1608 JB 1H 471K-T-A
C56	4030006910	S.CERAMIC	C1608 CH 1H 0R5C-T-A
C57	4030009520	S.CERAMIC	C1608 CH 1H 020B-T-A
C60	4550006350	S.TANTALUM	TEMSVB2 1A 226M-8L
C61	4030006960	S.CERAMIC	C1608 CH 1H 050C-T-A
C62	4340000180	S.MYLAR	ECHU 1C 333JB5
C63	4610002150	S.TRIMMER	CTZ3S-10A-W1-AF
C64	4030009660	S.CERAMIC	C1608 JF 1C 224Z-T-A
C65	4030006850	S.CERAMIC	C1608 JB 1H 471K-T-A
C67	4030011600	S.CERAMIC	C1608 JB 1C 104KT-N
C68	4550006590	S.TANTALUM	ECST1CY684R
C69	4030006860	S.CERAMIC	C1608 JB 1H 102K-T-A
C70	4030006850	S.CERAMIC	C1608 JB 1H 471K-T-A
C72	4030006850	S.CERAMIC	C1608 JB 1H 471K-T-A
C73	4030011600	S.CERAMIC	C1608 JB 1C 104KT-N
C74	4030006850	S.CERAMIC	C1608 JB 1H 471K-T-A
C75	4030006850	S.CERAMIC	C1608 JB 1H 471K-T-A
C76	4030006850	S.CERAMIC	C1608 JB 1H 471K-T-A
C77	4030007050	S.CERAMIC	C1608 CH 1H 220J-T-A
C78	4030007110	S.CERAMIC	C1608 CH 1H 680J-T-A
C79	4510004630	S.ELECTROLYTIC	ECEV1CA100SR
C80	4030009660	S.CERAMIC	C1608 JF 1C 224Z-T-A
C81	4030008920	S.CERAMIC	C1608 JB 1C 473K-T-A
C82	4030011600	S.CERAMIC	C1608 JB 1C 104KT-N
C83	4030008680	S.CERAMIC	C2012 JF 1C 105Z-T-A
C84	4030006850	S.CERAMIC	C1608 JB 1H 471K-T-A
C85	4550006480	S.TANTALUM	TEMSVA 1C 475M-8L
C86	4030011810	S.CERAMIC	C1608 JB 1A 224K-T-N
C87	4030011600	S.CERAMIC	C1608 JB 1C 104KT-N
C88	4550006250	S.TANTALUM	TEMSVA 1A 106M-8L
C89	4030009880	S.CERAMIC	C1608 JB 1H 682K-T-A
C90	4030006900	S.CERAMIC	C1608 JB 1E 103K-T-A
C91	4030008920	S.CERAMIC	C1608 JB 1C 473K-T-A
C92	4030006900	S.CERAMIC	C1608 JB 1E 103K-T-A
C93	4030006900	S.CERAMIC	C1608 JB 1E 103K-T-A
C95	4030006850	S.CERAMIC	C1608 JB 1H 471K-T-A
C96	4030006850	S.CERAMIC	C1608 JB 1H 471K-T-A
C101	4030006920	S.CERAMIC	C1608 CH 1H 010C-T-A
C102	4030009520	S.CERAMIC	C1608 CH 1H 020B-T-A
C201	4030006850	S.CERAMIC	C1608 JB 1H 471K-T-A
C202	4030007050	S.CERAMIC	C1608 CH 1H 220J-T-A
C203	4030007050	S.CERAMIC	C1608 CH 1H 220J-T-A
C204	4030006970	S.CERAMIC	C1608 CH 1H 060D-T-A
C205	4030006860	S.CERAMIC	C1608 CH 1H 102K-T-A
C206	4030006860	S.CERAMIC	C1608 JB 1H 102K-T-A
C207	4030006990	S.CERAMIC	C1608 CH 1H 080D-T-A
C208	4030007000	S.CERAMIC	C1608 CH 1H 090D-T-A
C209	4030006970	S.CERAMIC	C1608 CH 1H 060D-T-A
C210	4030006980	S.CERAMIC	C1608 CH 1H 070D-T-A
C212	4030006860	S.CERAMIC	C1608 JB 1H 102K-T-A
C215	4030006850	S.CERAMIC	C1608 JB 1H 471K-T-A
C216	4030009540	S.CERAMIC	C1608 CH 1H 1R5B-T-A
C217	4030006970	S.CERAMIC	C1608 CH 1H 060D-T-A
C218	4030006850	S.CERAMIC	C1608 JB 1H 471K-T-A
C219	4030006960	S.CERAMIC	C1608 CH 1H 050C-T-A
J1	6910007660	CONNECTOR	IMSA-9210B-1-02T
J2	6510018170	S.CONNECTOR	4-175643-4
W5	7030003860	S.JUMPER	ERJ3GE JPW V
W201	7030003860	S.JUMPER	ERJ3GE JPW V
W202	7030003860	S.JUMPER	ERJ3GE JPW V
EP1	0910051972	PCB	B 5421B
EP2	6910013310	S.BEAD	MMZ1608D121B

S.=Surface mount

SECTION 7 MECHANICAL PARTS AND DISASSEMBLY

[CHASSIS PARTS]

REF. NO.	ORDER NO.	DESCRIPTION	QTY.
SP1	2510000960	Speaker K036NA500-26	1
EP1	3310002110	Antenna 2123 ANT	1
MP1	8210015181	2045 front panel-1 [BLACK]	1
	8210016101	2045 front panel (A)-1 [YELLOW]	1
MP2	8210015191	2045 rear panel-1 [BLACK]	1
	8210016111	2045 rear panel (A)-1 [YELLOW]	1
MP3	8110006400	2045 rear cover [BLACK]	1
	8110006720	2045 rear cover (A) [YELLOW]	1
MP4	8110006410	2045 lock cover [BLACK]	1
	8110006730	2045 lock cover (A) [YELLOW]	1
MP5	8310042680	2045 window plate	1
MP7	8210015220	Panel 2045 reflector	1
MP8	8610010570	Knob N-265	1
MP9	8930045192	2045 top seal-2	1
MP10	8930045230	2045 4-key	1
MP11	8930045200	2045 PTT button	1
MP12	8930046990	2045 main seal (A)	1
MP13	8930045220	2045 BATT seal	1
MP14	8930046280	2045 ANT terminal	1
MP15	8930045350	2045 A-terminal	1
MP16	8930045360	2045 B-terminal	1
MP17	8930045370	2045 C-terminal	2
MP19	8930045740	2045 sheet	1
MP20	8830001370	2045 VR nut	1
MP22	8930045750	Seal O-ring (X)	1
MP23	8830000110	Nut M4	1
MP24	8810009560	Screw PH BO 2x6 ZK (BT)	4
MP25	8810008640	Screw FH BO 2x4 NI-ZU (BT)	2
MP27	8830001390	2045 insert nut	1
MP29	8930019790	891 terminal rubber	3
MP30	8810008990	Screw PH BO 2x10 ZK (BT)	1

[UNPACKING]

REF. NO.	ORDER NO.	DESCRIPTION	QTY.
MP1	8930045331	2045 belt clip-1	1
MP2	8820001040	2045 screw	1

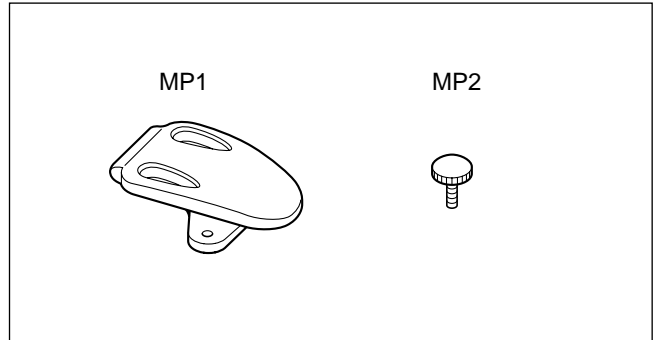

Screw abbreviations

- A, B0, BT: Self-tapping
- PH: Pan head
- FH: Flat head
- BiH: Bind head
- NI: Nickel
- SUS: Stainless
- ZK: Black

[MAIN UNIT]

REF. NO.	ORDER NO.	DESCRIPTION	QTY.
DS2	5030001750	LCD LD-BU10503J	1
EP1	8930045510	LCD contact SRCN-2045-SP-N-W	1
MP2	8510012840	2347 main shield	1
MP3	8930051770	2347 sheet	1

[RF UNIT]

REF. NO.	ORDER NO.	DESCRIPTION	QTY.
MP1	8510011570	2045 VCO case	1
MP2	8510012830	2347 RF-B shield	1
MP4	8510012820	2347 RF-A shield	1
MP5	893002930	Non-woven sheet	1

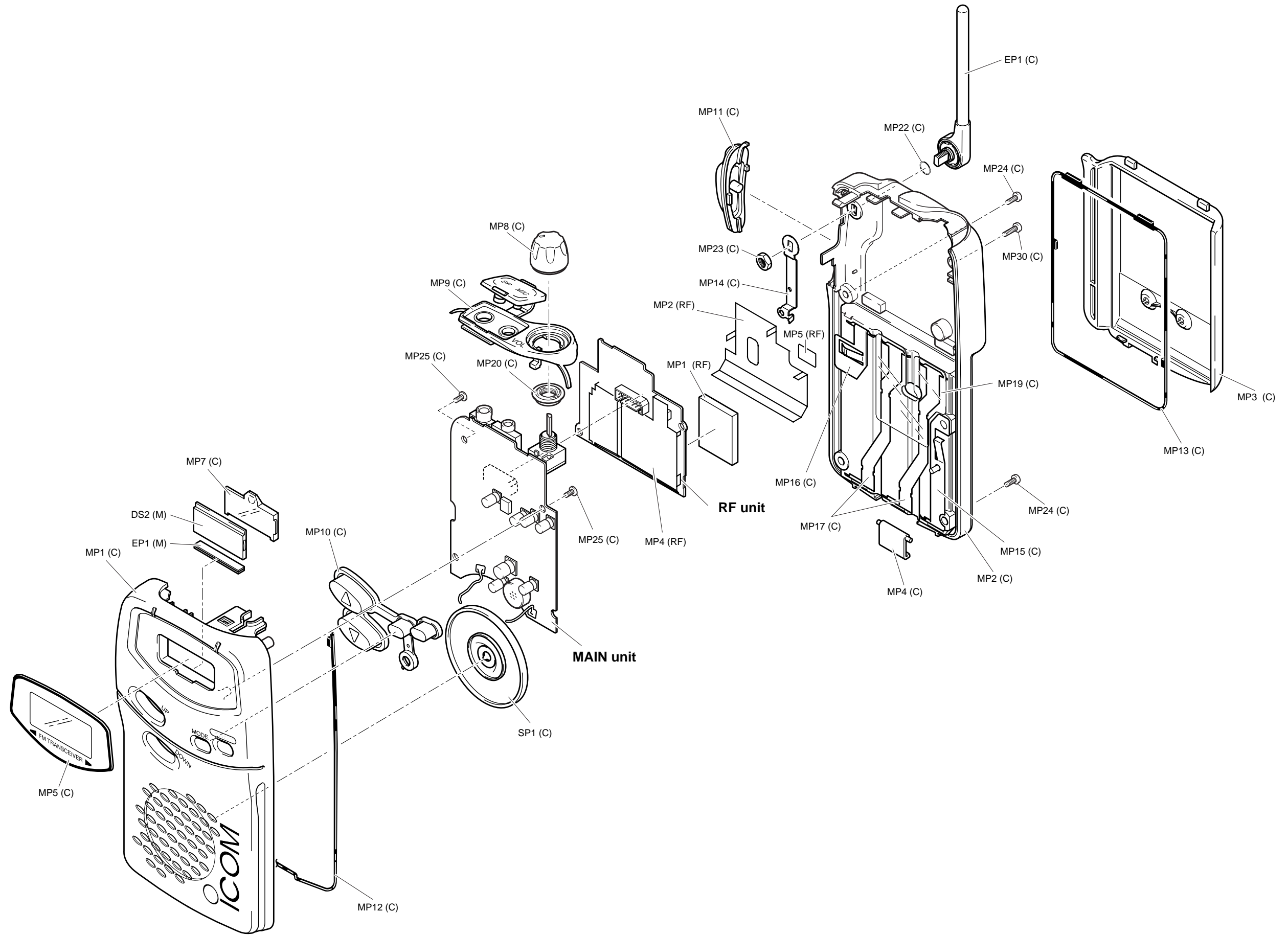

UNIT abbreviation (C): CHASSIS PARTS, (M): MAIN UNIT, (RF): RF UNIT

SECTION 8 SEMI-CONDUCTOR INFORMATION

• TRANSISTOR AND FET'S

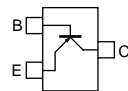
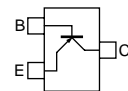
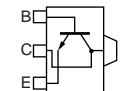
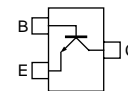
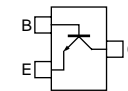
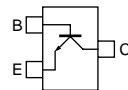
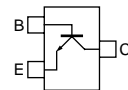
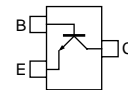
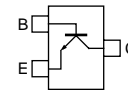
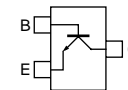
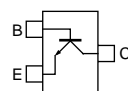
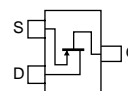
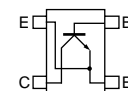
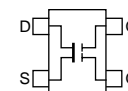
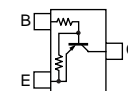
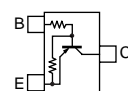
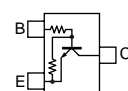
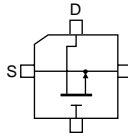
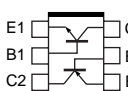
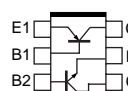
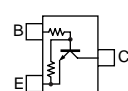
2SA1362-GR (Symbol: AEG) 	2SA1586-GR (Symbol: SG) 	2SB798-T2 DK (Symbol: DK) 	2SC3356 R24-T2B (Symbol: R24) 	2SC4081 T107S (Symbol: BS) 
2SC4213-B (Symbol: AB) 	2SC4215-O (Symbol: QO) 	2SC4226-T2 R25 (Symbol: R25) 	2SC4228-T2 R44 (Symbol: R44) 	2SC5006-T1 (Symbol: 24) 
2SC5108-Y (Symbol: MC) 	2SJ144-Y (Symbol: VX) 	2SK1829 (Symbol: K1) 	3SK284 (Symbol: U1) 	DTA144EUA T106 (Symbol: 16) 
DTA123JUA T106 (Symbol: 132) 	DTC114EUA T106 (Symbol: 14) 	XRF9482T1 (Symbol: 9482) 	UMZ1N TR (Symbol: Z1) 	UMZ2N TR (Symbol: Z2) 
UN9214 (Symbol: 8A) 				

• DIODES

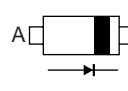
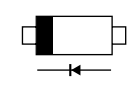
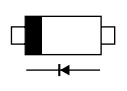
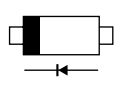
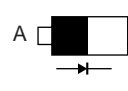
1SS355 TE-17 (Symbol: A) 	1SV284 (Symbol: TL) 	MA2S077 (Symbol: S) 	MA2S728 (Symbol: B) 	MA77 (Symbol: 4B) 
---------------------------------------------------------------------------------------------------------------------------	----------------------------------------------------------------------------------------------------------------------	----------------------------------------------------------------------------------------------------------------------	----------------------------------------------------------------------------------------------------------------------	--------------------------------------------------------------------------------------------------------------------

SECTION 9 BOARD LAYOUTS

9-1 MAIN UNIT

• TOP VIEW

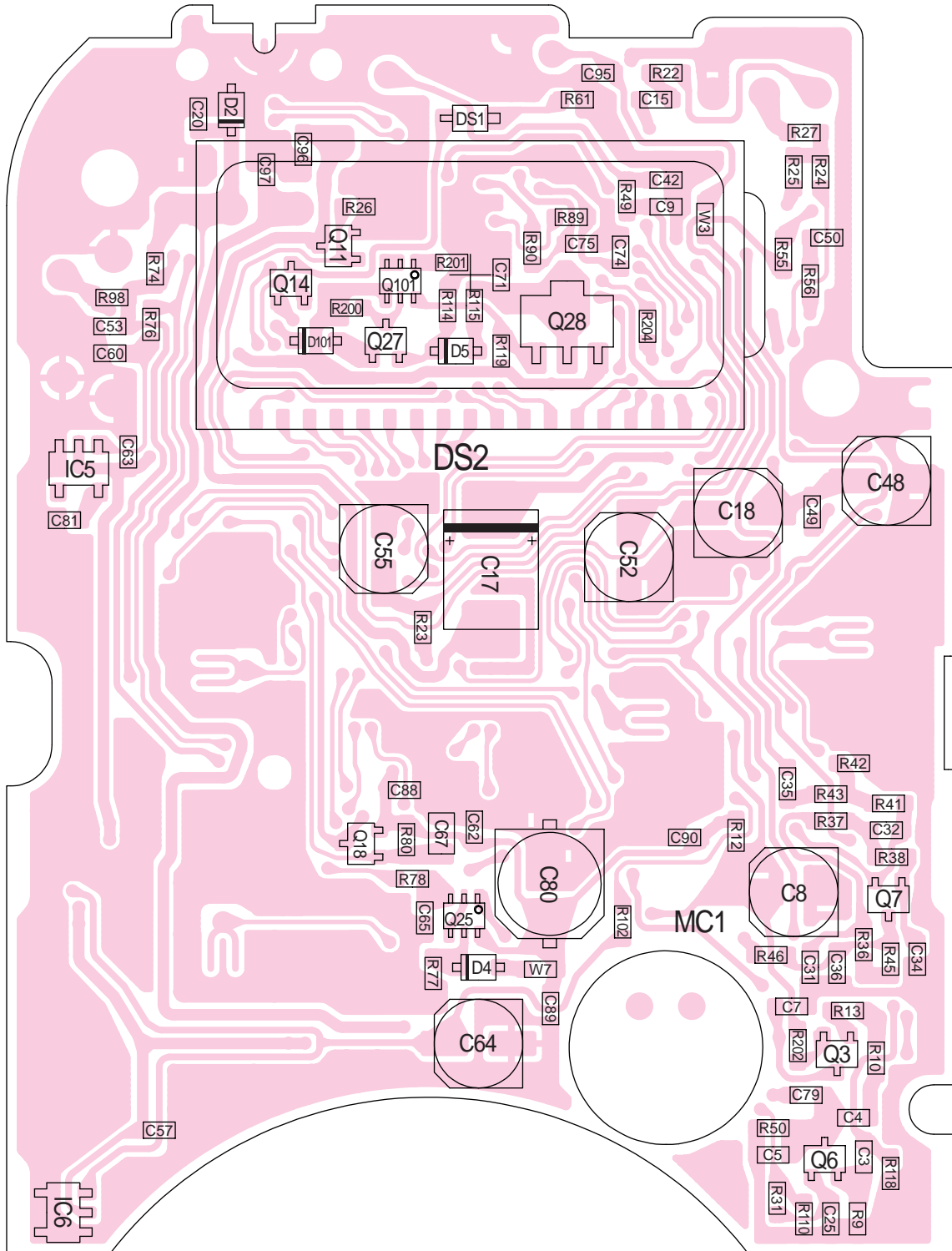

● BOTTOM VIEW

J4	1	13
	SHIFT	AF
	CK	
	DATA	
	STB	
	SQL	
	R+3	SENS
2	GND	14

to RF unit J2

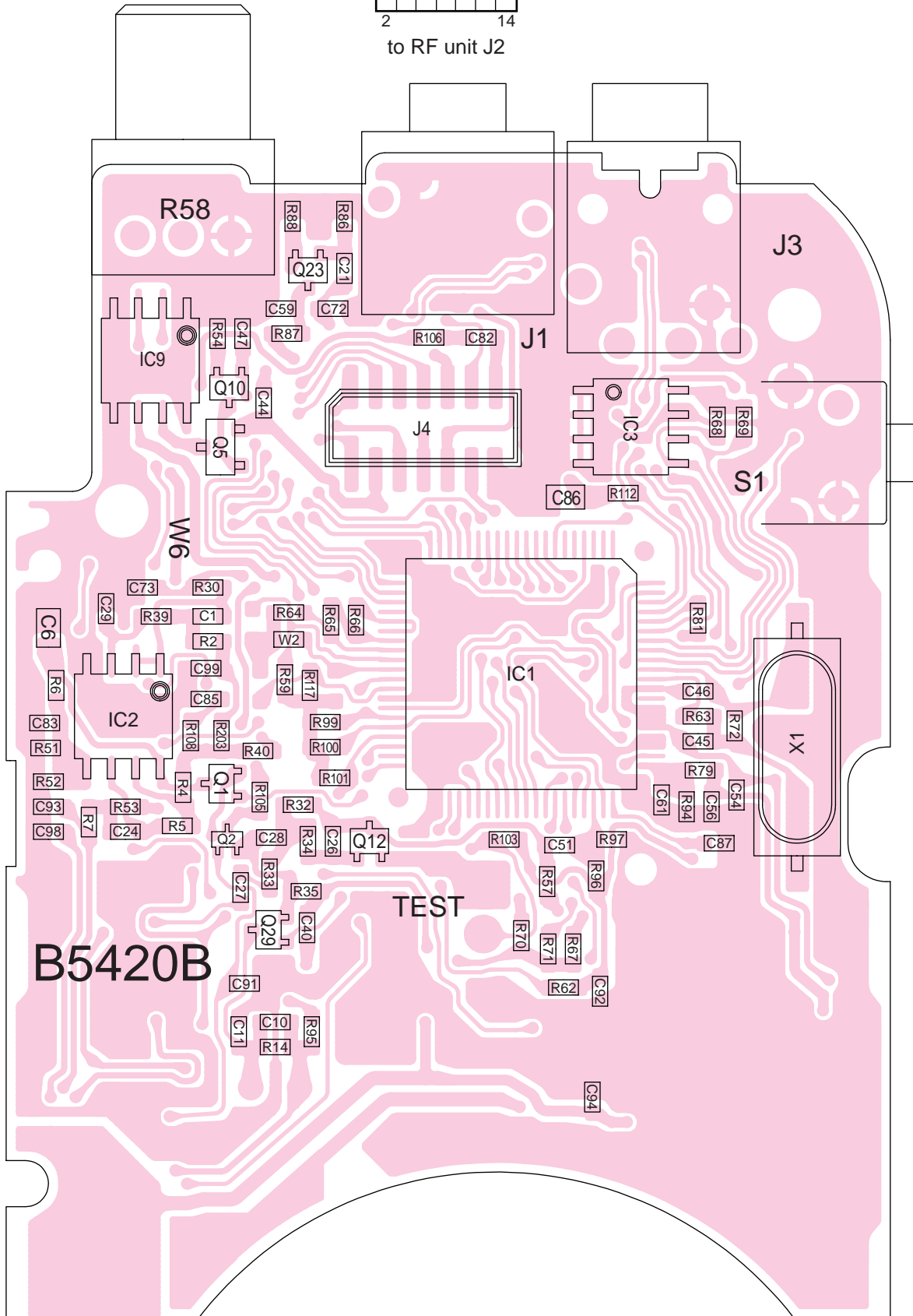

9-2 RF UNIT

- TOP VIEW

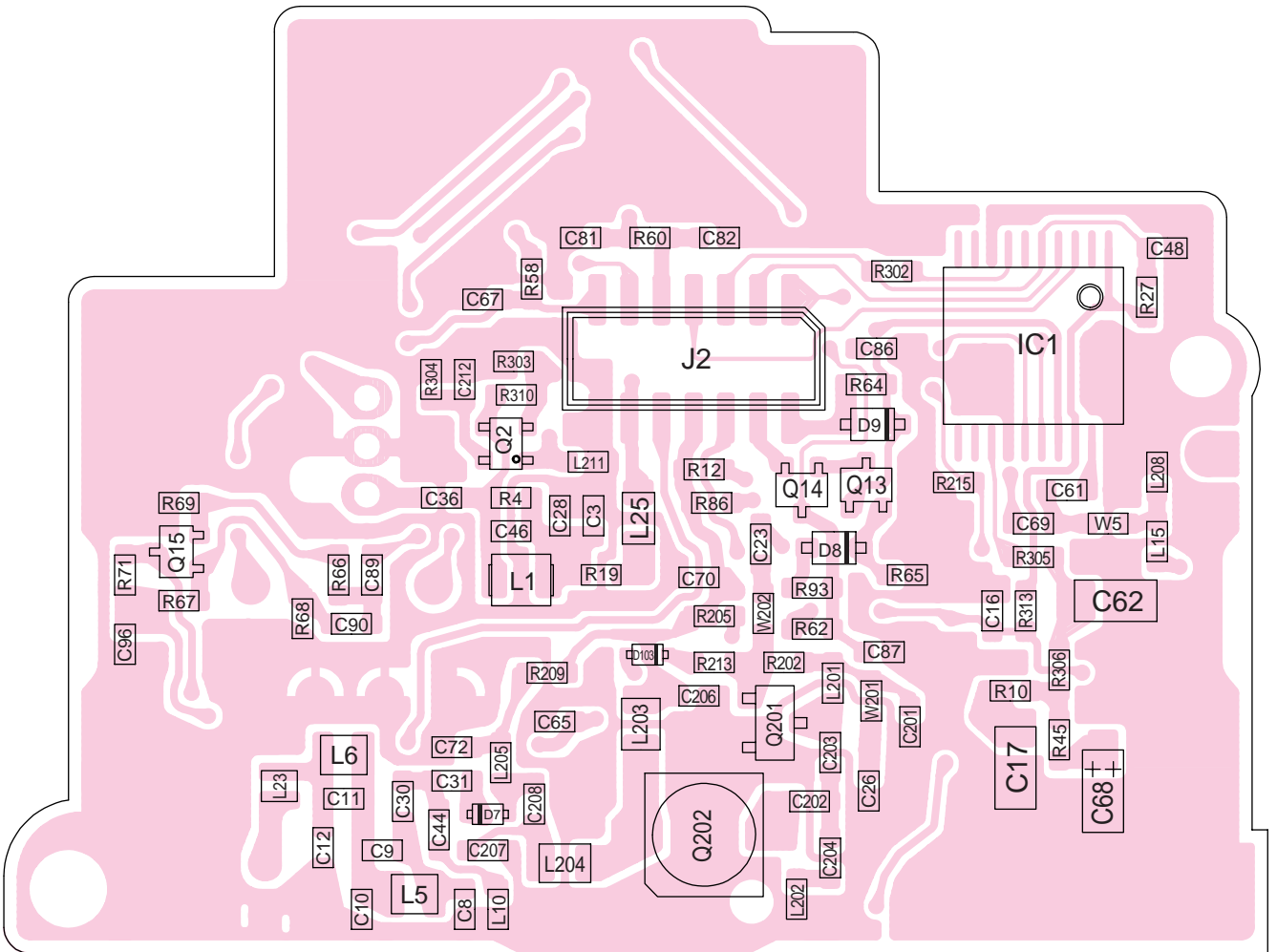
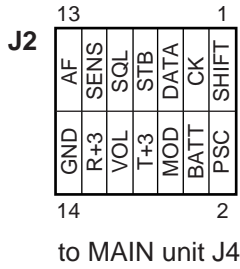

● BOTTOM VIEW

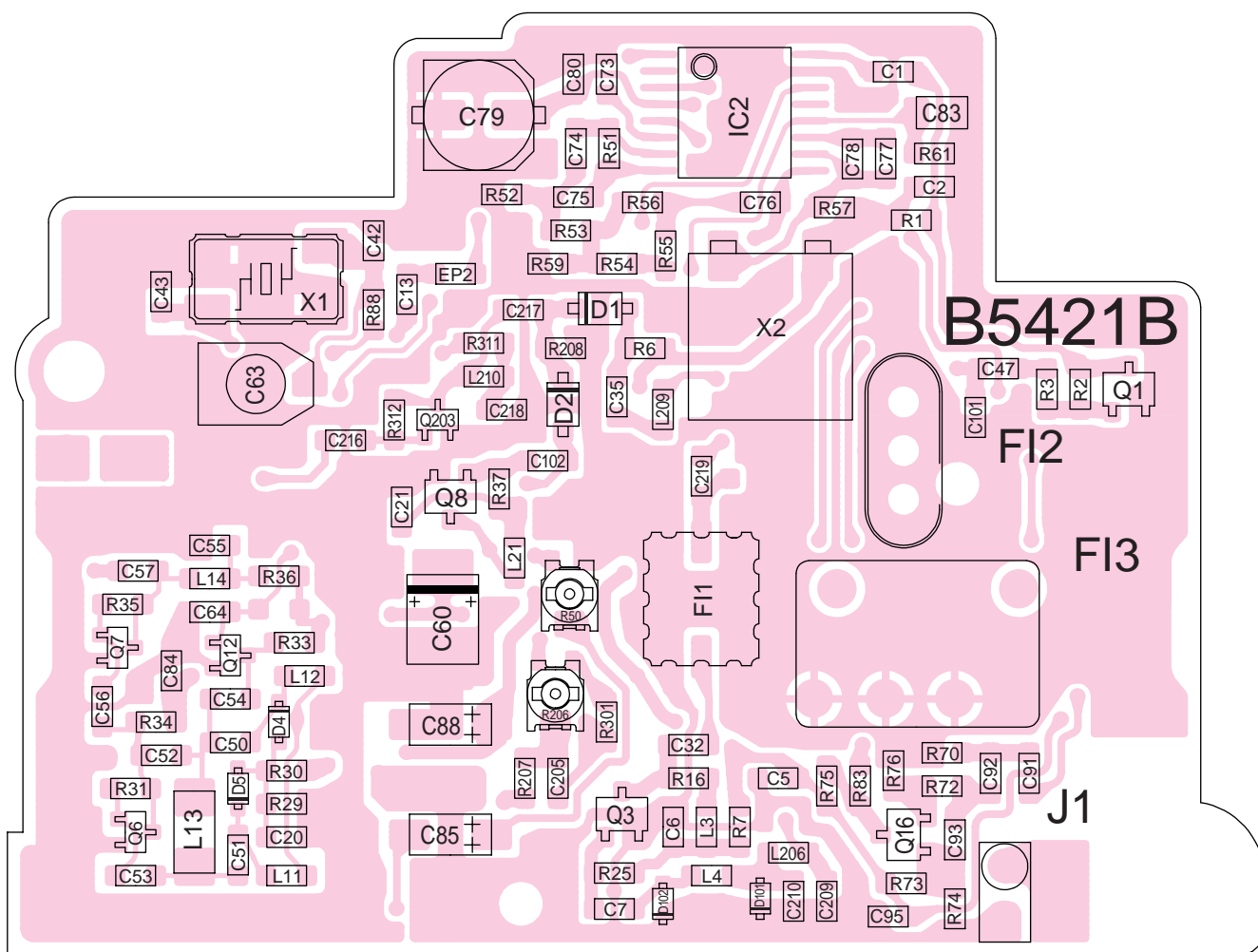

SECTION 10 BLOCK DIAGRAM

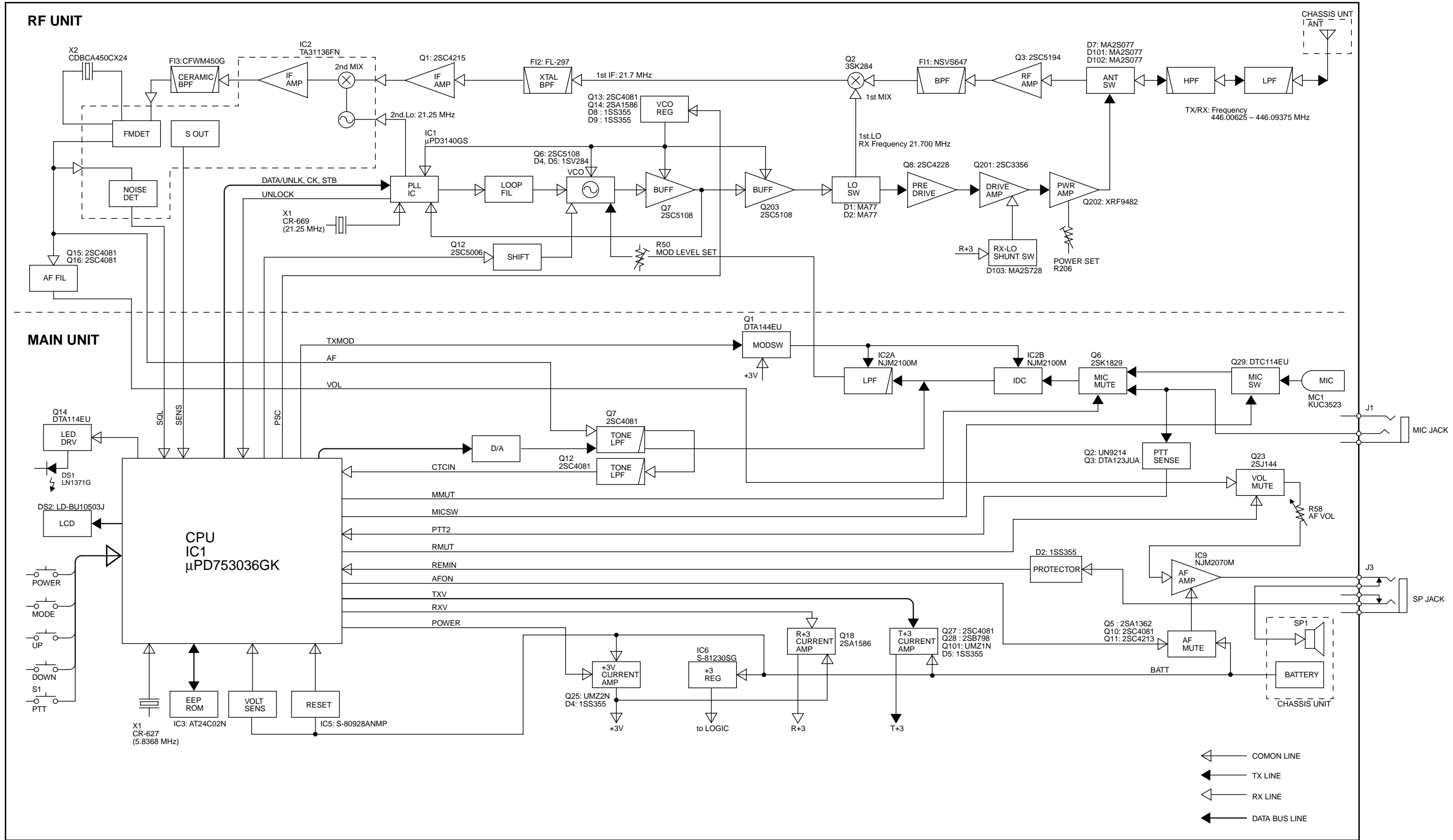

11-2 RF UNIT

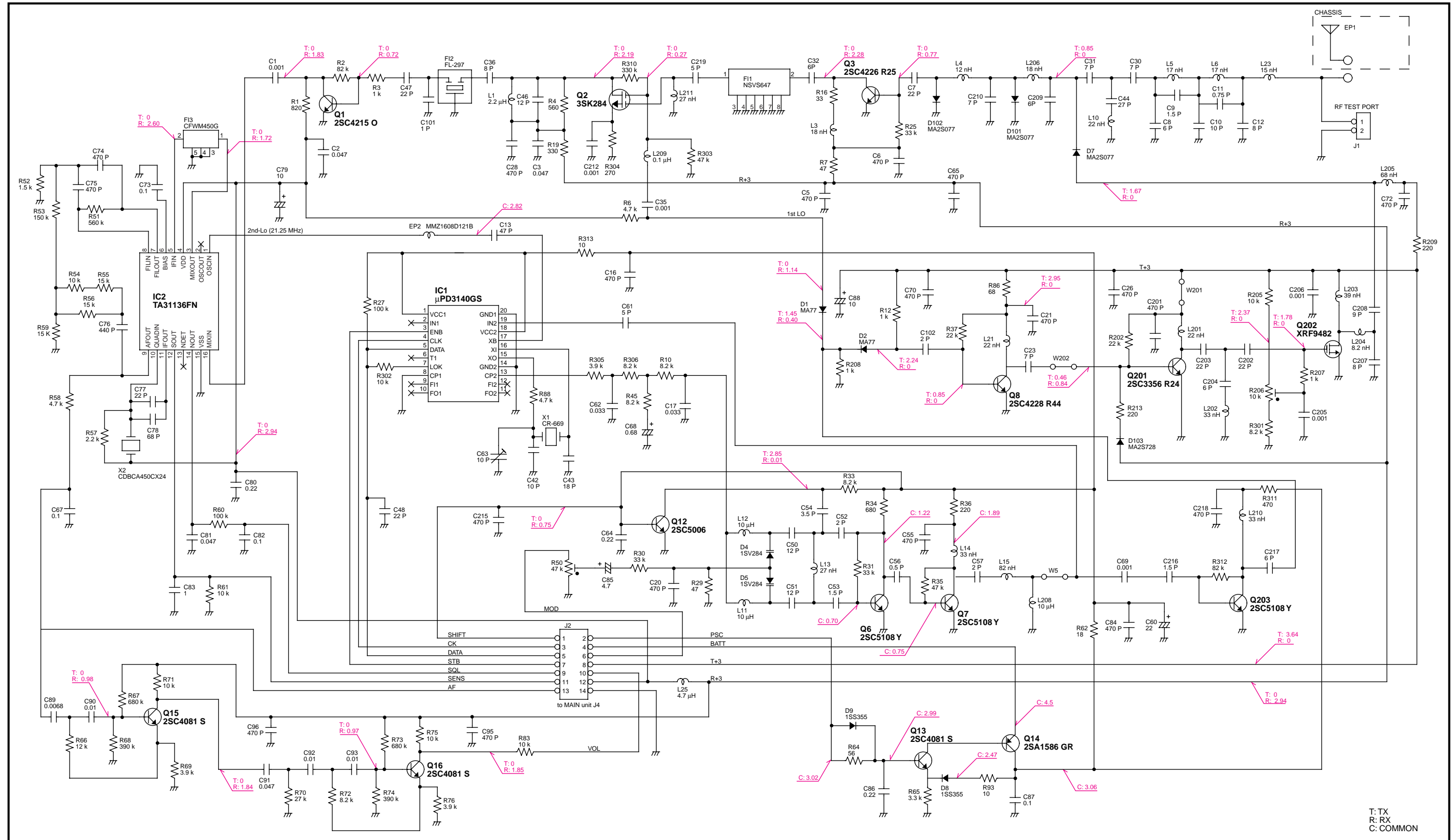

Icom Inc.

6-9-16, Kamihigashi, Hirano-ku, Osaka 547-0002, Japan
Phone : 06 6793 5302
Fax : 06 6793 0013

Icom America Inc.

<Corporate Headquarters>
2380 116th Avenue N.E., Bellevue, WA 98004, U.S.A.
Phone : (425) 454-8155 Fax : (425) 454-1509
URL : <http://www.icomamerica.com>
<Customer Service>
Phone : (425) 454-7619

Icom Canada

3071 #5 Road, Unit 9, Richmond, B.C., V6X 2T4, Canada
Phone : (604) 273-7400 Fax : (604) 273-1900
URL : <http://www.icomcanada.com>

Icom (Australia) Pty. Ltd.

A.C.N. 006 092 575
290-294 Albert Street, Brunswick, Victoria, 3056, Australia
Phone : 03 9387 0666 Fax : 03 9387 0022
URL : <http://www.icom.net.au>

Asia Icom Inc.

6F No. 68, Sec. 1 Cheng-Teh Road, Taipei, Taiwan, R.O.C.
Phone : (02) 2559 1899 Fax : (02) 2559 1874

Icom (Europe) GmbH

Communication Equipment
Himmelgeister Str. 100, D-40225 Düsseldorf, Germany
Phone : 0211 346047 Fax : 0211 333639
URL : <http://www.icomeurope.com>

Icom Spain S.L.

Crta. de Gracia a Manresa Km. 14,750
08190 Sant Cugat del Valles Barcelona, SPAIN
Phone : (93) 590 26 70 Fax : (93) 589 04 46
URL : <http://www.icomspain.com>

Icom (UK) Ltd.

Unit 9, Sea St., Herne Bay, Kent, CT6 8LD, U.K.
Phone : 01227 741741 Fax : 01227 741742
URL : <http://www.icomuk.co.uk>

Icom France S a

Zac de la Plaine, Rue Brindejonc des Moulinais
BP 5804, 31505 Toulouse Cedex, France
Phone : 561 36 03 03 Fax : 561 36 03 00
URL : <http://www.icom-france.com>

Count on us!